

USER´S MANUAL
GARIA GOLF, VIA, MONACO



G A R I A

1. INTRODUCTION

Congratulations on your new Garia Vehicle. Garia is dedicated to creating the best and most elegant leisure vehicle in the world. We have been uncompromising in our vision and have thought of every detail to build a vehicle that meets all your needs and expectations with direct focus on functionality.

This Garia User's Manual contains important information that you will need for the proper operation and handling of your Garia Vehicle.

This User's manual covers the VIA, Monaco and Golf Car vehicle

We encourage you to read this and manual thoroughly before operating your Garia.

If you have additional questions regarding operation or maintenance of your Garia, please contact your local Authorized Garia Service Dealer for immediate support.

Thank you for choosing Garia.

After Sales and Support Department
Garia A/S
Lunikvej 44
DK-2670 Greve
Denmark
support@garia.com

Garia user's manual.

© 2020 by Garia A/S

5st Edition

All rights reserved. Any reprinting or unauthorized use without the written permission of Garia A/S is expressly prohibited.

Copyrighted material.

This manual may not be reproduced in whole or in part without the express permission of Garia A/S, After Sales and Support Department

Printed in Denmark

G21 982 001 03 Garia user's manual

CONTACT

Garia A/S Support and After Sales (International)

Phone: +45 46 570 580

Fax: +45 46 590 599

Lunikvej 44

DK-2670 Greve

Denmark

shop.garia.com

CONTACT U.S.

Garia Inc. Technical Assistance and Service Parts

Phone: +1 281 923 0291

Fax: +1 281 936 0300

13810 Hollister, Suite 150

Houston, Texas 77086

United States

For service inquiries:

service@garia.com

For warranty inquiries:

warranty@garia.com

For support, repair and other general inquiries:

support@garia.com

Find your local contact at:

www.garia.com

Garia A/S and Garia Inc. reserves the right to make design changes without obligation to make these changes on units previously sold.

The information contained in this manual is subject to change without notice.

Garia A/S or Garia Inc. is not liable for errors in this manual or for incidental or consequential damages that result from the use of the material in this manual.

REPORTING SAFETY DEFECTS (U.S. ONLY)

If you believe that your vehicle has a defect which could cause a crash or could cause injury or death, you should immediately inform the National Highway Traffic Safety Administration (NHTSA) in addition to notifying Garia Inc.

If NHTSA receives similar complaints, it may open an investigation, and if it finds that a safety defect exists in a group of vehicles, it may order a recall and remedy campaign. However, NHTSA cannot become involved in individual problems between you, your dealer, or Garia Inc.

To contact NHTSA, you may call the Vehicle Safety Hotline toll-free at: 1-888-327-4236 (TTY: 1-800-424-9153);

Additional information can be found at:
<http://www.safercar.gov>

To contact NHTSA write to:
Administrator
NHTSA
400 Seventh Street, SW
Washington, DC 20590

You can also obtain other information about motor vehicle safety from
<http://www.safercar.gov>

To contact Garia, please write to:
Garia A/S
Phone: +45 46 570 580
Fax: +45 46 590 599
Lunikvej 44
DK-2670 Greve
Denmark

email:
support@garia.com

www.garia.com

IMPORTANT SAFETY INFORMATION

Particularly important information is emphasized in this manual by the following notations:



The Safety Alert Symbol means ATTENTION! BE ALERT! YOUR SAFETY IS INVOLVED!

DANGER

Failure to follow DANGER instructions could result in severe injury or death to the vehicle occupants, a bystander, or a person inspecting or repairing the vehicle.

WARNING

Failure to follow WARNING instructions could result in severe injury or death to the vehicle occupants, a bystander, or a person inspecting or repairing the vehicle.

CAUTION

Failure to follow CAUTION instructions could result in damage to the vehicle, or the surroundings.

NOTE

This message provides additional important information.

WARNING

Read and understand the manual completely before operating your Garia vehicle.

NOTE

Garia A/S is continually making enhancements or improvements in design or quality which are applied to its products. This manual contains all available information on the current product at the time of printing, however, there can be minor differences between your Garia vehicle and this manual. If you have any questions concerning this manual or your Garia product, please consult your Garia A/S.

This manual is to be considered a permanent part of the Garia vehicle. Hence, it should always follow the vehicle, including when it is resold.

WARNING

Be aware, when operating on public roads, that this vehicle offers significantly less crash protection compared to normal cars, vans, trucks or other motorized vehicles. This will result in a higher risk of injuries or death in collisions, at any speed. Especially in areas with heavy traffic or traffic with higher speeds.

To reduce the risk of injuries or accidents, follow the guidelines below:

- All passengers must always wear seatbelts at all times.
- Always reduce speed when driving on hills or when cornering, to reduce the risk of vehicle tipping over or passengers falling out.
- NEVER operate while under the influence of alcohol and/or drugs.

IMPORTANT NOTE

Always operate this Garia vehicle in compliance with your country and local vehicle regulations including registration, titling, insurance, seat belt usage, and operator's licensing.

Turn ignition switch to the off position and remove key before leaving the vehicle.

Always fasten your seat belts!

To extend the life of your batteries:

- Keep the vehicle plugged into the charger even during long absences. The charger recognizes the charging needs, and will keep the batteries in peak condition without causing any damage.
- Avoid deep discharging of batteries at all possible times.



Fig. 1.2

Maintenance Warning Label. Read before maintaining vehicle.
Label placed in the battery compartment. Label size may vary.

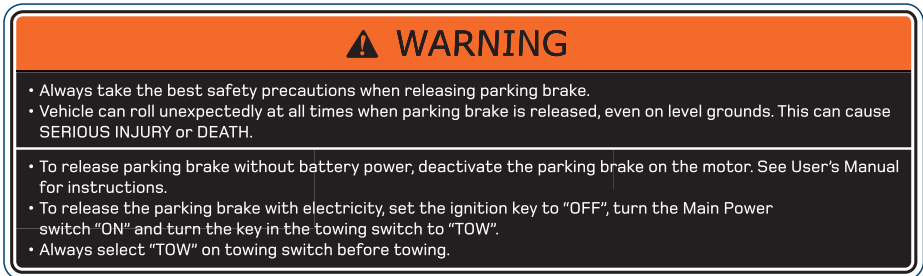

Fig. 1.4

Towing Warning Label. Read before towing vehicle.
Label placed in the battery compartment. Label size may vary.



Fig. 1.5

Battery Warning Label. Read before handling batteries.
Label placed in the battery compartment. Label size may vary.

TABLE OF CONTENTS

01 WARRANTY

1. Warranty	1
-------------------	---

02 SAFETY

2. Safety	2
2.1 Garia VIA and Monaco	2
2.2 Garia Golf car	2
2.3 Check-ups before use	3
2.3.1 Batteries	3
2.3.2 Tire conditions	4
2.3.2.1 Checking tire pressure	4
2.3.2.2 Checking tire wear	4
2.3.3 Body and chassis	5
2.3.4 Brakes	5
2.3.5 Steering	6
2.3.6 Reverse warning indicator (Except Garia Monaco)	7
2.3.6.1 Pedal operation	8
2.3.6.2 Accelerator pedal	8
2.3.6.3 Brake pedal	9
2.4 In use Garia Golf car and Courtesy	10
2.4.1 In use Garia Via and Monaco	11
2.4.2 Driving in terrain or on roads	12
2.4.3 Driver qualifications	13
2.4.4 Safety precautions when maintaining the vehicle	13
2.4.5 Maintenance to ensure safety	14
2.4.6 Mirrors	15
2.4.7 Seatbelts Roadster and LSV	16
2.4.8 Seatbelts Via and Monaco	17
2.4.9 Rear Seatbelts on 2+2 models	18

03 BATTERIES

3.1 Battery Safety Warning and Instructions	19
3.1.1 Battery safety	20
3.2 General Information	21
3.3 Charging of batteries	21
3.4 Charger LED	22
3.5 Lithium Batteries (Optional)	23
3.5.1 Relion lithium battery maintenance instructions	24

3.6 Equipment for handling batteries	25
3.7 Battery maintenance and care	25
3.7.1 Watering batteries.	26
3.7.2 Using the HydroLink™ on-board water filler system	26
3.7.3 Using the flow-rite hand pump.	27
3.7.4 Preventive maintenance.	29
3.7.5 Cleaning batteries	30
3.7.6 Removing corrosion from battery poles	30
3.8 Storage of batteries	30
3.8.1 Storage in hot environments (higher than 90°F (32°C))	30
3.8.2 Storage in cold environments (less than 32°F (0°C)).	30
3.8.3 Water supplies	31
3.8.4 Watering system	31
3.9 General information about Trojan® batteries.	31

04 OPERATION

4.1 Overview	32
4.2.1 Overview Golf car	33
4.2.2 Overview Monaco	34
4.2.3 Overview Via	35
4.2.3 Overview 2+2 edition.	36
4.3 Speed switch (Optional).	37
4.4 Instrument cluster notifications	38
4.4.1 Critical battery level	38
4.4.2 Currently no messages.	38
4.4.3 Do not turn vehicle off for 2 min.	38
4.4.4 Reduced power	39
4.4.5 Service due	39
4.4.6 Battery discharge indicator	39
4.5 Ignition switch	40
4.6 Main power switch	41
4.7 Parking brake.	42
4.8 Driving, accelerating	43
4.9 Stopping, Braking	44
4.10 Rough terrain driving	45
4.11 Hill hold and roll back	46
4.12 Emergency braking	46
4.13 Motor braking.	47
4.14 Braking with parking brake	47

05 VEHICLE EQUIPMENT

5. Vehicle equipment	48
5.1 Dashboard overview	48
5.2 Below the seats:	49
5.2 Seats	49
5.3 Instrument cluster functions and warning lamps	50
5.3.2 Button on instrument cluster (left)	51
5.3.1 Inner cluster explanation	51
5.3.3 Button on Instrument cluster (right)	52
5.4 Indicator stalk	53
5.5 Airscoop	54
5.5.1 Opening and closing the air scoop	54
5.6 Storage room under bonnet	55
5.7 Bin	56
5.8 Multifunctional rear section	57
5.9 Adjusting rear view mirror	58
5.10 Refrigerator and Storage box	59
5.10.1 Energy saving tips	59
5.10.2 Defrosting the refrigerator	59
5.11 Interior light (Optimal / standard on Via and Monaco)	60
5.12 Windshield wiper/washer (optional / standard on Via and Monaco)	61
5.13 Heated windscreen (Optional)	62

06 SERVICE

6.1 Service Intervals	63
6.2 Service symbol in Instrument cluster	63
6.3 Service actions	64
6.4 User Self-service	65

07 MAINTENANCE

7.1 Replacing light bulbs	66
7.2 Replacing the bulb for the front position light	67
7.3 Jack points	68
7.4 Changing a wheel	69
7.5 Cleaning the vehicle	70
7.5.1 Exterior	70
7.5.2 Wheels	70
7.5.3 Rubber flooring	70
7.5.4 Interior	71
7.5.5 Seats	71
7.5.6 Battery maintenance and care	71

7.6 Controlling the brake fluid	72
7.7 Tow switch	73
7.8 Towing without battery power.....	74
7.9 Towing hook	75
7.10 Hauling.....	75
7.11 Fuse box location	76
7.11.1 Fuse box layout	77

08 TROUBLESHOOTING

8. Troubleshooting	78
8.1 The car will not drive.....	78
8.2 The vehicle will only drive at a very slow speed.....	78
8.3 The vehicle has a lower range than usual.....	78
8.4 The Charger will not charge the batteries.....	78
8.5 What to do with a completely flat battery.....	78
8.6 How to reset the vehicle.....	79
8.7 The lights do not work	79
8.8 The refrigerator does not work	79
8.9 The refrigerator stops cooling when parked (less than 2 hours)	79
8.10 The brake pedal is soft, or goes down without resistance.....	79
8.11 The vehicle vibrates in the steering wheel.....	79

09 VEHICLE TECHNICAL SPECIFICATIONS

9. Vehicle Dimensions	80
-----------------------------	----

10 SERVICE BOOK

NOTES	83
-------------	----

1. Warranty

In order to uphold the warranty it is important that all service actions are performed according to the intervals specified by Garia.

Please contact your local dealer for any questions regarding your Garia. To locate your nearest dealer, please visit the website at www.garia.com

2. Safety

It is important to read and understand this Garia manual and along with all safety and instruction labels, before the vehicle is first used. Be aware of the noise level on this vehicle is very low and pedestrian can have a hard time hearing the vehicle.

2.1 Garia VIA and Monaco

- Read "Check-ups before use"
- This Street legal version is constructed to operate at 40 km/h (25 mph)
- This vehicle is only to be driven by people with a valid drivers lincens.
- Always drive the vehicle from the driver's side only and only in areas intended for the usage of this type of vehicle.
- The vehicle is equipped with seat belts. Always keep seat belts fastened whenever seated and the vehicle is in motion.
- Never allow more than one passenger in each seat.
- Do not operate while under the influence of alcohol and/or drugs.
- Do not make any modifications or additions to the vehicle which influences its loading capacity or safe use. Do not make any changes to the vehicle that are not in accordance with the user's manual.
- Be aware, when operating on public roads, that this vehicle offers significantly less crash protection compared to normal cars, vans, trucks or other motorized vehicles. This will result in a higher risk of injuries or death in collisions, at any speed. Especially in areas with heavy traffic or traffic with higher speeds.

2.2 Garia Golf car

- Read "Check-ups before use" which is found in the following pages of this manual and perform these accordingly.
- This vehicle is only to be driven by people trained in and authorized to using this type of vehicle, always from the driver's side only and only in areas intended for the usage of this type of vehicle.
- Never allow more than one passenger in each seat. This vehicle is restricted to two (2) occupants including the driver.
- Do not operate while under the influence of alcohol and/or drugs.
- Do not drive the vehicle on public areas and roads. Some communities have special regulations about driving this type of vehicle on public streets, always be sure to observe the specific rules and regulations of the areas and communities where the vehicle is being used.
- Do not make any modifications or additions to the vehicle which influences its loading capacity or safe use. Do not make any changes to the vehicle that are not in accordance with this user's manual.

2.3 Check-ups before use

Before the vehicle is put into service, the following points of this section should always be followed to ensure the optimal, safe and correct operation of the vehicle. It is a good idea to make it a habit to follow these checkpoints every time the vehicle is used.

Before using the vehicle, please check the following

1. Batteries
2. Tire conditions
3. Body and chassis
4. Brakes
5. Steering
6. Pedal operation

2.3.1 Batteries

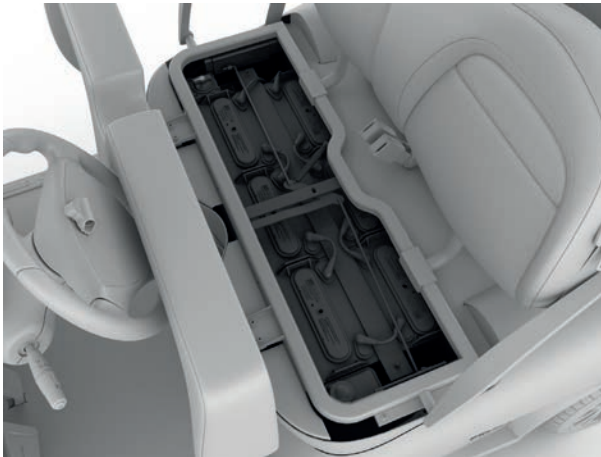

Fig. 2.1

- Check that all wires are connected and mounted correctly.
- Check that no corrosion is present on the battery poles.
- Check that the compartment is dry and free from acid or water spills.
- Check that batteries are placed correctly and held down by the battery bracket.

2.3.2 Tire conditions

2.3.2.1 Checking tire pressure

It is of great importance that the tire pressure is checked and adjusted regularly before using the vehicle.



Fig. 2.2

2.3.2.2 Checking tire wear

Check tire surface for damages, cracks and foreign objects. When tire thread wears down to 2,0 mm (0,08 in.), it is recommended that the tire is replaced. Please check local legislation for minimum requirements of tire treads.

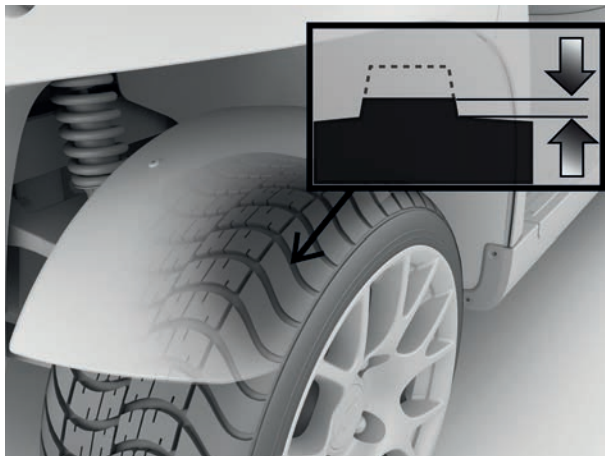

Fig. 2.3

2.3.3 Body and chassis

Always visually inspect the chassis and body to make sure that all chassis and body parts are present, correctly mounted and undamaged before using.

Check that all electrical functions are working correctly. This includes:

- Headlamps, both high and low beam
- Position lights
- Turning signal indicators
- Horn
- Hazard lights
- Windshield wiper/washer (Standard on Via and Monaco)
- Reflectors front and back (Standard on Via and Monaco)

2.3.4 Brakes

Always make sure that brakes are functioning correctly. Do not drive, if brakes are not functioning correctly.

When engaging the brake pedal, the pedal should show resistance after being depressed approximately 1/3 of its way. If it is possible to push the brake to the floor without any resistance, it is an indication of a malfunction in the braking system. Please consult a qualified repair shop immediately. It is recommended that repairs are provided by an Authorized Garia Service Dealer. The pedal should feel firm at all times and always return to its original position when released.

WARNING

Always ensure that the ignition switch is turned "OFF" before the pedal operation is tested. Vehicle can accelerate abruptly if vehicle is set to the "F" or "R" position and potentially cause severe injury to persons or damage to property. Do not drive if brakes are not working correctly.

2.3.5 Steering



Fig. 2.4

Check steering for excessive free play:

Before driving:

- Turn steering wheel slightly left and right.

If too much free play is observed, or any unusual sounds appear from any of the components, consult a qualified repair shop. Garia recommends that maintenance is provided by an Authorized Garia Service Dealer.

2.3.6 Reverse warning indicator (Except Garia Monaco)



Fig. 2.5

Control the reverse warning indicator function by selecting "R" on the ignition switch and reversing slowly. Make sure to operate safely and with sufficient space when reversing. The audio warning signal should be activated. If it does not activate, please consult a qualified repair shop. It is recommended that maintenance is provided by an Authorized Garia Service Dealer.

2.3.6.1 Pedal operation

Perform the following check on the pedal operation to ensure that pedals are working correctly as specified below.

WARNING

Always ensure that the ignition switch is turned “OFF” before the pedal operation is tested. Vehicle can accelerate abruptly if vehicle is set to the “F” or “R” position and potentially cause severe injury to persons or damage to property.

2.3.6.2 Accelerator pedal

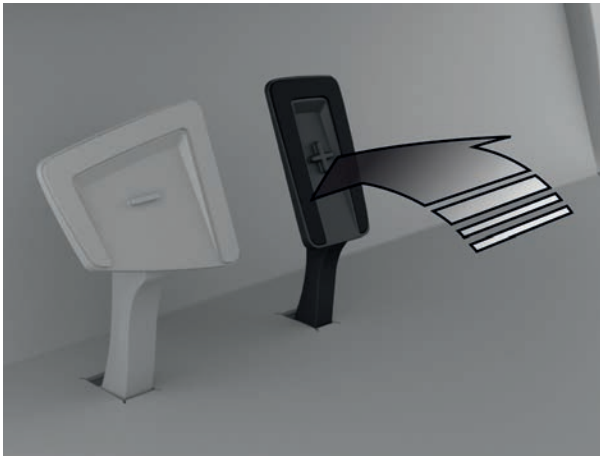

Fig. 2.6

Before driving, ensure that (with the ignition key turned to “OFF”):

- The accelerator pedal is working correctly and moving freely.
- The pedal returns to its original position when released. The original position is when the pedal is positioned as illustrated above.

2.3.6.3 Brake pedal



Fig. 2.7

Before driving, ensure that:

- The brake pedal feels firm and cannot be pressed more than $\frac{2}{3}$ of the total pedal travel distance.
- The pedal returns to its original position when released. The original position is when the pedal is positioned as illustrated above.

WARNING

Always ensure that the ignition switch is turned “OFF” before the pedal operation is tested. The vehicle can accelerate abruptly if the vehicle is set to the “F” or “R” position and potentially cause severe injury to persons or damage to property.

2.4 In use Garia Golf car and Courtesy

- Keep the entire body inside the vehicle at all times. Remain fully seated and hold on to speed handles or other objects while driving.
- Do not start vehicle until all passengers are fully seated.
- The driver must keep both hands on the steering wheel and the eyes focused in the direction in which the vehicle is driving.
- Show extra caution in populated areas or when reversing. Always reverse slowly and pay attention to the road and surroundings.
- The vehicle might not be as visible in the night time. Always make sure to turn on the headlamps and tail lights whenever operating from dusk to dawn.
- Avoid accelerating or decelerating in an abrupt manner.
- Always adjust the speed to the current terrain.
- Drive slowly when making turns and when going up and down slopes. Never turn steering wheel sharply at higher speeds.
- Never drive on slopes at an angle, use brakes to reduce speed when driving downhill.

Vehicles can cause serious injury or damage if used improperly or not maintained according to the vehicle's maintenance program. Before the vehicle is put into service, all necessary safety precautions must be taken and all the additional rules and regulations of the area where the vehicle is being used must be observed.

Vehicles should be safe to use as long as the safety precautions explained in this user's manual and on the vehicle are upheld. Make sure that the vehicle is always driven according to the current conditions and adjust the speed and driving pattern according to the terrain in which the vehicle is currently moving.

It is expected that many vehicles will be used for a variety of tasks beyond the original intended use of the vehicle. As a consequence of this, it is impossible to anticipate and warn against every possible combination of circumstances that may occur. No warnings can take the place of good common sense and prudent driving practices.

2.4.1 In use Garia Via and Monaco

- Each driver must carry a valid driver's license.
- Keep entire body inside vehicle at all times. Remain fully seated and hold on to handles or other objects while driving.
- The vehicle is equipped with seat belts. Always keep seat belts fastened whenever seated.
- Follow all traffic regulations and obey all rules and regulations.
- Do not start vehicle until all passengers are fully seated and fastened.
- Do not carry children on laps or in children's seats, the vehicle is not constructed for transporting children requiring a child safety seat.
- Do not allow anyone to hang onto the vehicle at any time.
- The driver must keep both hands on the steering wheel and the eyes focused in the direction in which the vehicle is driving.
- Show extra caution in populated areas or when reversing. Always reverse slowly and pay attention to the road and surroundings.
- The vehicle might not be as visible in the night time. Always make sure to turn on the headlamps and tail lights whenever operating from dusk to dawn.
- Avoid accelerating or decelerating in an abrupt manner.
- Always adjust the speed to the terrain where the vehicle is currently used.
- Drive slowly when making turns and when going up or down slopes. Never turn steering wheel sharply at higher speeds to reduce the risk of the vehicle tipping over or to prevent possible injury to an unsuspecting passenger.
- Never drive up or down slopes at an angle, use brakes to reduce speed when driving downhill.

The Garia Via and Monaco can cause serious injury or damage if used improperly or not maintained according to the vehicle's maintenance program. Before the vehicle is used, all necessary safety precautions must be taken and all the additional instructions of the area, where the vehicle is used, must be observed.

The Garia Via and Monaco should be safe to use as long as the safety precautions explained in the user's manuals and on the vehicle are upheld. Make sure that you always drive according to the current conditions and adjust the speed and driving pattern according to the terrain in which the vehicle is moving.

It is expected that many vehicles will be used for a variety of tasks beyond the original intended use. As a consequence of this, it is impossible to anticipate and warn against every possible combination of circumstances that may occur. No warnings can take the place of good common sense and prudent driving practices.

2.4.2 Driving in terrain or on roads

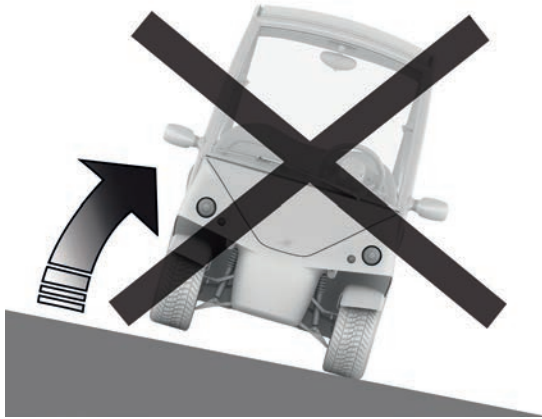

Fig. 2.8

- Hills: Driving up and down steep hills and slopes should be avoided or at a minimum driven with the highest level of caution. If driving down hills or slopes is a necessity, do this as slowly as possible while braking with the brake pedal. Furthermore, driving must not be at an angle that makes the vehicle tilt sideways.
Warning: Risk of falling out!
Avoid parking the vehicle on hills or tilted at an angle. Always make sure to park the vehicle on as level grounds as possible.
- Sharp or blind bends: Use great caution around sharp or blind bends, adjust the speed, so the turn can be made in a safe manner. Be prepared to stop the vehicle or avoid possible obstacles if dangerous situations occur.
- Wet areas: Driving on wet grass or similar areas reduces the contact between the vehicle and the surface and can cause instability. Hence, always drive slowly and with caution, so you are always driving in a safe manner.

WARNING

Always ensure to drive carefully at all times. Driving fast, irresponsibly or in any way not according to referred to in this user's manual can cause severe injuries or death to persons and property damage.

2.4.3 Driver qualifications

The driver of the vehicle should as a minimum have read this complete user's manual, have full knowledge and understanding of the use of this vehicle and be in possession of a valid driver's license for motor vehicles.

The driver is required to drive responsibly and safely, in order to avoid damage to property and/or injuries to others or him-/herself.

The driver must know about the rules and regulations for driving vehicles of the area where the vehicle is operated, and must follow these at all times. No persons under the age of 16 shall be allowed to operate the vehicle.

In areas with pedestrians and other traffic, the driver must exercise caution, drive slowly and pay attention to the surroundings.

For the Gara leisure vehicle, it is a legal requirement that all drivers of this vehicle have a valid driver license. The Gara street legal models is fitted with seat belts and it is required that these are fastened when the vehicle is in motion.

2.4.4 Safety precautions when maintaining the vehicle

When maintaining the vehicle, make sure to follow all safety precautions located on the vehicle, described in this user's manual, in the Gara Workshop Repair Manual and especially the following:

- Ensure that the vehicle has been properly secured and cannot move, when vehicle is being maintained.
- Ensure that the vehicle has the correct lifting support before any repair and maintenance is carried out.
- Avoid fire hazards and ensure that there is proper fire extinguishing equipment within reach.
- The electrical system must be disconnected before ANY work is carried out on this vehicle. (See chapter 4 for instructions on disconnecting power)
- Make sure that warning and information labels are in a readable condition. If any label needs replacing to make the vehicle conform to the correct safety standards, please consult a qualified repair shop. It is recommended that maintenance is provided by an Authorized Gara Service Dealer.
- Always use correct insulated tools when working on and around electrical installations, such as batteries, on the vehicle.

- Maintain all components that have an effect on safety and the safe operation of the vehicle. This particularly includes the brakes, steering and warning devices.
- After each repair, service or other maintenance, the vehicle must be test driven by qualified and authorized personnel on a specifically designed area, without pedestrians or other traffic, to ensure that the vehicle is adjusted correctly and functions as specified.
- Ensure that all maintenance service checks are filled out correctly in the applied Warranty and Service book.

2.4.5 Maintenance to ensure safety

To sustain safety it is important that the vehicle is maintained correctly, and the following is recommended to follow to obtain the best possible safety.

- Maintenance is preventative: Always service and maintain the vehicle according to maintenance schemes stated in this user's manual. By doing this, the car will attain the highest level of safety and the warranty will be upheld. (See chapter 6 and 7 of this manual) If the specified service intervals are not adhered to, all applicable warranties will be void.
- Repairs: Allow only qualified, educated and authorized personnel to inspect, service and repair the vehicle. All applicable warranties will be void, if repair procedures are not followed as described in the Garia Work Shop and Repair Manual.

2.4.6 Mirrors

The Garia street legal vehicles comes with factory fitted mirrors and they are adjustable for the optimal viewing conditions and enhancing safety while driving.

Adjust the rearview mirror before driving.

Do not adjust mirrors while driving. This takes focus off the driving and can create dangerous situations. The Via models are fitted with a Rear view display mirror (reverse camera)



Fig. 2.9

To adjust the mirrors, move adjustment lever in side the vehicle



Fig. 2.10



Fig. 2.11

⚠ CAUTION

Make sure not to bend the mirror excessively in any direction as this can cause permanent damage to the mirror.

2.4.7 Seatbelts Roadster and LSV

This Garia Monaco Roadster (Europe only) and LSV is equipped with 2-point seat belts. Ensure that all passengers have their seat belts fastened before putting the vehicle into movement. The seat belt must at all times be worn snugly around the body. The seat belt shall **not** be tensioned around any other objects, e.g. the armrest, than the person wearing the seat belt. Each seat belt assembly is constructed for **one** person only. Always make sure to follow these instructions and those located on the vehicle, before operating the vehicle.

Note: If the passenger's feet are not touching the floor, make sure to show extra caution when operating the vehicle. Always make sure that children are completely secured from falling out of the vehicle, before driving the vehicle.

⚠ WARNING

ALWAYS wear seatbelts correctly when driving. Failure to do so, can cause serious injuries or death in case of an accident.

Pull seat belt out in a straight and even movement before placing it around the body. Use left seat belt for the left seat and the right for the right hand side.



Fig. 2.12



Fig. 2.13



Fig. 2.14

Correct positioning, fasten seatbelt inside of the armrest.



Fig. 2.15

Wrong positioning, do not fasten seatbelt outside of the armrest.

2.4.8 Seatbelts Via and Monaco

This Garia Via and Monaco is equipped with three-point seat belts. Ensure that all passengers have their seat belts fastened before putting the vehicle into movement. The seat belt must at all times be worn snugly around the body. The seat belt shall not be tensioned around any other objects, e.g. the armrest, than the person wearing the seat belt. Each seat belt assembly is constructed for one person only. Always make sure to follow these instructions and those located on the vehicle, before operating the vehicle.

Note: If the passenger's feet are not touching the floor, make sure to show extra caution when operating the vehicle. Always make sure that children are completely secured from falling out of the vehicle, before driving the vehicle.

⚠ WARNING

ALWAYS wear seatbelts correctly when driving. Failure to do so, can cause serious injuries or death in case of an accident.



Fig. 2.16



Fig. 2.17

2.4.9 Rear Seatbelts on 2+2 models

All the Garia 2+2 models are equipped with 2-point seat belts. Ensure that all passengers have their seat belts fastened before putting the vehicle into movement. The seat belt must at all times be worn snugly around the body. The seat belt shall **not** be tensioned around any other objects other than the person wearing the seat belt. Each seat belt assembly is constructed for **one** person only. Always make sure to follow these instructions and those located on the vehicle, before operating the vehicle.

Note: If the passenger's feet are not touching the floor, make sure to show extra caution when operating the vehicle. Always make sure that children are completely secured from falling out of the vehicle, before driving the vehicle.

⚠ WARNING

ALWAYS wear seatbelts correctly when driving. Failure to do so, can cause serious injuries or death in case of an accident.



Fig. 2.1

3. Batteries

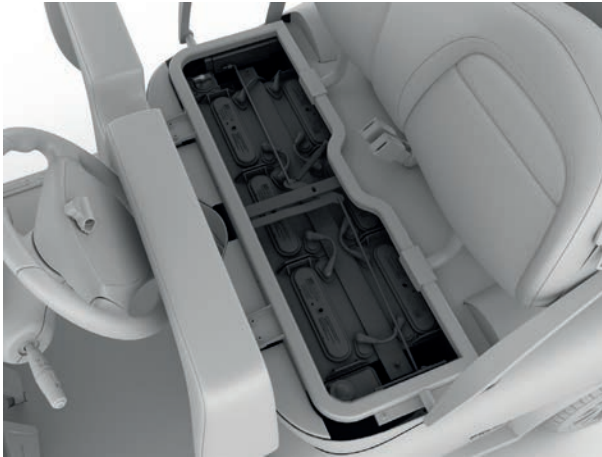

Fig. 3.1

3.1 Battery Safety Warning and Instructions

Please read and comply with all of the following safety-related instructions and warnings prior to operating and maintaining the batteries in this vehicle. Failure to comply with these instructions may result in serious personal injury, death and/or property damage.

DANGER

EXPLOSIVE GASES!

- Batteries generate explosive gases! Do not smoke in the vicinity of any batteries.
- Keep sparks and flames away from the batteries, vehicle and service area.
- Ventilate the area when charging batteries or operating a vehicle in an enclosed space.
- Wear a full face shield and rubber gloves when working on or near batteries.
- Keep flames, sparks, cigarettes and fire away from batteries at all times. The gas exhaust from the batteries causes fire and explosions. This will cause **SERIOUS INJURY** or **DEATH**.

RISK OF ELECTRIC SHOCK!

- The electricity stored in batteries can cause electric shock resulting in serious bodily injury or death, even at low voltages.
- Use insulated tools when working near batteries or electrical connections.
- Use extreme caution to avoid short circuiting of components or wiring.
- Do not wear metal jewelry such as rings, watches, chains, etc., when servicing the vehicle, watering system, battery or battery charger.

3.1.1 Battery safety

- Check that all connections and battery cables are securely attached to the terminal and tightended according to specification; too loose or too tight connections can result in post breakages, meltdown or fire.
- Do not place any objects on batteries or terminals to avoid short circuits.
- Keep sparks, flames and metal objects away from batteries.
- The electrolyte is a solution of acid and water, so avoid skin contact.
- If acid comes into contact with your skin or eyes, flush with water immediately and seek medical attention.
- Charge batteries in a well-ventilated area, as batteries produce gas fumes when charging. Lift seat cushion to vertical position when charging.
- Never add acid to the battery.

WARNING

Battery electrolyte is poisonous and dangerous, causing severe burns or other damages. It contains sulfuric acid. Avoid contact with skin, eyes or clothing.

Do not transport, store, handle or operate batteries except in an upright position.

Wear a full face shield and rubber gloves when working on or near batteries

Emergency treatment:

EXTERNAL: Flush with water immediately

INTERNAL: Drink large quantities of water or milk. Follow with milk of magnesia, beaten egg, or vegetable oil. Seek medical attention.

EYES: Flush with water for 15 minutes and acquire prompt medical attention.

Batteries produce explosive gases. Keep sparks, flames cigarettes or similar away from the batteries. Seek medical attention.

Always ensure proper ventilation when charging or using in enclosed space. Always shield eyes when working near batteries.

KEEP OUT OF REACH OF CHILDREN.

3.2 General Information

The Garia comes standard with six 8 Volt lead acid batteries which provides the power for its operation. To ensure the best operation, always make sure that the vehicle is maintained according to specified maintenance intervals. The batteries used in this vehicle are Trojan® T-875 T2. The batteries are made of 65% water and 35% acid with an electrolyte plate inside the battery.

3.3 Charging of batteries

Always follow the safety precautions mentioned below to avoid personal injury or death or property damage when maintaining or storing batteries:

- Always follow procedures that are in accordance with applicable laws and regulations when charging and using charging facilities.
- Periodically inspect the facilities and the procedures used when charging and storing batteries to ensure that the correct safety conditions are in place.
- The vehicle shall only be charged using a vehicle-specific Garia charging cable. The cable is according to the provisions of UL standards 2202.

Only charge batteries with the integrated Delta-Q on-board charger. This charger is equipped with algorithms that allow the most optimal charging session at any state of charge. It is carefully designed for the vehicle's batteries. Do not attempt to charge batteries in other ways than by using the integrated on-board charger. By using other chargers, the risk of over- and undercharging occurs, which can shorten the capacity of the batteries and potentially destroy them. The integrated on-board charger is programmed to maximize battery performance.

The optimal charging time depends on a range of different factors. It is expected that the battery can charge from a 30% state to a fully charged state in approximately 7 hours. This is, however, dependent on the weather conditions, the state of charge and the general condition of the batteries.

When charging batteries, please be aware of the following:

- Batteries shall be fully charged after each use, if not this will damage the batteries over time.
- Lead-acid batteries do not have a memory effect and therefore do not need to be fully discharged before recharging.
- Charge only in well-ventilated areas
- The batteries will gas (bubble) towards the end of charge to ensure the electrolyte is properly mixed.
- Never charge a frozen battery
- Avoid charging at temperatures above 120°F (49°C)
- Only apply distilled water after charging

3.4 Charger LED



Fig. 3.2

The charger LED is located **1** on the left side of the dashboard, just in front of the airduct, when connecting the charger cable the LED will blink red-yellow-green. This indicates that the DeltaQ charger has registered the power input and can start to charge the batteries. When charging and the voltage on the batteries are below 80% state the charger LED will blink green repeatedly. When the total voltage exceeds 80% state of charge the LED blink green slowly, when 100 % state of charge the LED will stay illuminated with the green color to indicate that the charging session is done.

In case of a charger malfunction the DeltaQ charger LED will blink red X amount of times indicating the fault code on the charger, if this happens please contact the nearest Garia dealer for further support.

3.5 Lithium Batteries (Optional)



Fig. 3.3

General

Always turn ignition key to “OFF” when car is not in use. Car can drain battery in 1-2 days if ignition key is left in “R,N or F”. To restart car, find your nearest dealer at garia.com

Regular use of car

Connect charger to wall socket after each use to ensure full state of charge. Charger will maintain the battery and must always be connected when car is not in use. This will ensure optimum battery performance and charge the batteries daily. If car is not connected to the wall socket it will slowly lose the state of charge until the box shuts down automatically after 7 days where the battery will be almost flat. To restart the car after an automatic shutdown, swing open seat cushion and press the contact on the battery box in passenger side. The blue light on the box will turn on and box will make a “click” noise. Now connect charger cable to wall socket for a full charge before car is used.

Storage of car (no usage in 14 days or more)

Connect charger cable and charge car fully (solid green light in charger LED next to cable).

Disconnect charger cable.

Swing open seat cushion and shut down the battery box by pressing the contact on the battery box in passenger side. The blue light on the box will turn off and box will make a “click” noise.

To restart the car after a storing period, swing open seat cushion and press the contact on the battery box in passenger side. The blue light on the box will turn on and box will make a “click” noise. Now connect charger cable to wall socket for a full charge before car is used.

In the event of needing to TOW/PUSH the car

Red main switch (under seat) must be “ON”.

Tow switch next to main switch turned to “TOW”.

Lithium battery must be “ON” (blue light from battery box next to main switch.)

Turn ignition key to “N”. Car can now be towed / pushed.

3.5.1 Relion lithium battery maintenance instructions

3 important things when owning a Relion lithium powered Garia vehicle:

Daily Charging Procedure

Plug the charger cable into the charger socket on the dashboard once a day, allowing for a full charge, approximately 6-8 hours.

(Full charge = The LED, next to charger socket on dashboard, lights up solid green).

Storing Garia “short term” (between weekends)

Plug the charger cable into the charger socket on dashboard and leave it plugged in. The battery charger will monitor the voltage while plugged in and charge the battery when needed.

Storing the Garia for “long term” (more than a week)

Turn off the battery by pressing and holding the on/off button on the battery for 7 seconds until the box makes a “click” noise and the blue light in the button turns on.

Battery on/off button is located on the top of the battery, under the seat on the passenger side:

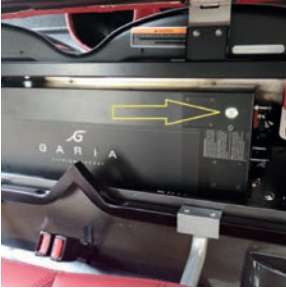

To turn on the battery: Press the on/off button on top of the battery until it makes a “click” noise and the light in the button comes on.

Make sure to charge the car after a period without use.

Note: The battery will automatically shut down after 7 days without use, if not plugged into a wall socket. To start using the car again, the battery must be manually turned on as described above.

GARIA BEST PRACTICE:

A couple of hours before you need to use your car, unplug the charging cable, wait 15 seconds and re-insert it. The charger will now re-detect if it is necessary to charge the battery and you will get the best performance from your lithium powered Garia.

3.6 Equipment for handling batteries

- Goggles, gloves and protective clothing: Always wear protective clothing, acid-proof gloves and goggles when handling lead acid batteries and remove all jewelry. Batteries are corrosive and failure to follow the above mentioned may result in personal injury or death as lead acid can cause severe burns and destroy clothing. Jewelry is a risk if it comes in contact with the terminals of the battery. Metals in contact with battery poles can cause arcs which can result in severe personal injuries.
- Distilled or treated Water (i.e. de-ionized, reverse osmosis, etc.)
- Rubber hand held wrench
- Volt meter (for testing voltage)
- Retightening the battery posts are very important to insure that malfunctions are kept at a minimum. Always use a torque wrench to tighten the battery posts, the correct amount of torque is 12 Nm or 8.8 ft./lbs.

Handling of batteries should not occur if the user has no prior experience of handling batteries. Please refer to Trojan® Battery's website for more information regarding battery handling: www.TrojanBattery.com

CAUTION

Always keep baking soda and great amounts of water nearby. This will help neutralize any possible acid spills from battery openings and prevent corrosive damage on batteries and the vehicle. Avoid all skin contact with acid.

3.7 Battery maintenance and care

Maintaining batteries properly includes always charging batteries after use, ensuring the correct level of fluid in the batteries as well as general removal of corrosion, dust, dirt and/or similar, apply anti corrosion liquid if needed.

WARNING

Watering a battery before charge (or with a low charge level) can lead to boil-over resulting in potential bodily injury and potential damage to the watering system, battery and vehicle.

Ensure that the work area is dry when servicing the vehicle, watering system, battery or battery charger.

3.7.1 Watering batteries

The batteries need to be watered periodically. The frequency depends upon battery usage and operating temperatures. Check new batteries every few weeks to determine the watering frequency of the vehicle. It is normal for batteries to need more watering as they age.

Depending on the local climate, charging methods, application, etc. it is recommended that batteries are checked at least once a month until they provide information on how often the batteries need refilling.

Important things to remember:

1. Do not fill the batteries with water before charging. This will increase risk of acid overflow from the battery, consequently losing capacity and causing corrosion.
2. Do not use water with a high mineral content. **Use distilled or deionized water only.** **Fully charge the batteries prior to adding water.** Only add water to discharged or partially charged batteries if the plates are exposed, and only until the plates are no longer exposed.

3.7.2 Using the HydroLink™ on-board water filler system

Lead acid batteries require frequent refilling of **distilled or deionized water**. The Garia Car is equipped with the Trojan® HydroLink™ Watering system, which eases the refilling of water to the batteries. An approved Flow-Rite water supply is required for correct refilling of the batteries,

Use only the approved Flow-Rite water supply that came with the vehicle, if the Flow-Rite water supply did not come with vehicle please contact the nearest Garia dealer.

Use of unapproved water supply or modification of approved water supply can lead to system failure and will void applicable warranties.

Only fill batteries after they have been fully charged, and require water. Watering a battery before charge (or with a low charge level) can lead to boil-over resulting in potential bodily injury and potential damage to the watering system, battery and vehicle.

WARNING

If at any time during the filling process a valve failure occurs, disconnect immediately or too much water may be added to the cell. This can cause the battery to overflow acid, causing corrosion and potential personal injury or damage to batteries.

3.7.3 Using the flow-rite hand pump

To operate the hand pump enclosed for watering the batteries, please follow the procedure below.

Note: Other Flow-Rite products recommended for the Trojan® HydroLink™ Watering system can also be used. Please see www.flow-rite.com for more information.

STEP 1

Check hand pump for proper operation. Insert the hand pump filler assembly into a jug of distilled water. Prime bulb by squeezing until it is filled with water. Ensure that the device is free of holes or other defects.

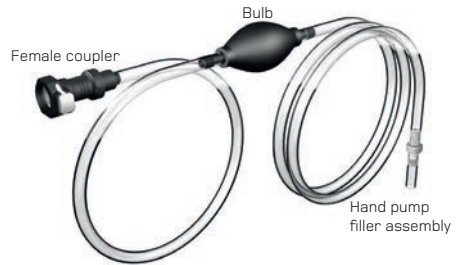

Fig. 3.4

STEP 2

Remove the dust cover on the battery hose.

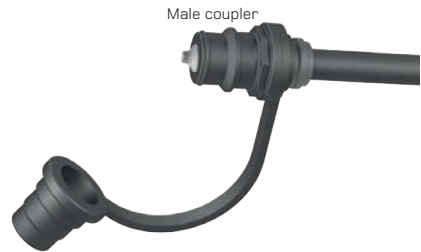

Fig. 3.5

STEP 3

Mate Couplers

Insert the male coupler on the HydroLink™ Watering System into the female coupler on the Flow-Rite Hand pump.



Fig. 3.6

03 BATTERIES

STEP 4

Fill water to batteries.

Squeeze the bulb with firm pressure to begin pumping water into the battery cells. When the bulb becomes firm, all cells are full and filling is complete.



Fig. 3.7

STEP 5

Disconnect

When the bulb becomes firm, and not before, immediately disconnect the couplers by depressing the push button on the female coupler. Disconnecting before the bulb becomes firm will lead to under-filled cells that will impact the battery's performance and shorten its life.

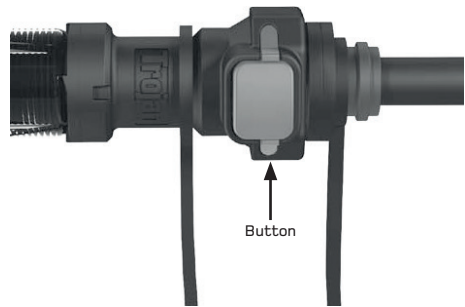

Fig. 3.8

STEP 6

Replace dust cover

Place dust cover back over the male coupler. Do not push cover past the large barb on the coupler.

TIP: If the dust cover is slightly squeezed when sliding it over the coupler, it will create a vacuum, allowing it to hold tightly.



Fig. 3.9

3.7.4 Preventive maintenance

Inspection of batteries

- Examine the outside appearance of the battery. Check the tops of the battery and terminals. These needs to be clean, free of dirt, debris and corrosion.
- Make sure the outside of the batteries remain dry at all times.
- If any fluids are present on the battery top, this could indicate that the battery is being over-watered or that a malfunction in the Trojan® HydroLink™ System has appeared. If so, contact your local repair shop, as there may be a problem with the installation and it needs to be serviced. Only allow a trained battery service technician to service batteries. It is recommended that battery maintenance is provided by a trained Authorized Garia Service Dealer in order to ensure the best possible treatment of the vehicle.
- Check battery cables and connections, ensure that all connections are in good working order and replace connections that are damaged and/or worn. Tighten all loose connections. It is recommended that battery maintenance is provided by a trained Authorized Garia Service Dealer in order to ensure the best possible treatment of the vehicle.
- Electrolyte levels: It is recommended that the electrolyte levels are checked in each cell after the system has been installed and operational for three months. Use the 'Independent Water Level Indicator' to check the electrolyte levels. HydroLink™ comes with an Independent, non-mechanical Water Level Indicator that is simple to read: white means that the battery needs water and black means that the battery has enough water.



Your HydroLink™ Watering System requires regular preventative maintenance on at least a quarterly basis.

Fig. 3.10

Inspect the condition of all tubing connections and couplers and the water filling system

Make sure that all parts are in good working condition and are secure, leak free and properly connected. The coupler must have an O-ring and dust cover properly attached.

3.7.5 Cleaning batteries

- Clean the top of the battery, the terminals, and all connections with a cloth or brush with a solution of baking soda and water (ensure that none of the baking soda solution gets inside of the battery). Use 1lb of baking soda for 1 gallon of water (120g for 1 litre of water).
- Rinse with plain water and dry the battery
- If possible, add a thin layer of terminal protector (Available at most battery dealers or auto parts stores).
- Always keep batteries dry and clean.

3.7.6 Removing corrosion from battery poles

Make sure that the poles and the surface of batteries are clean at all times. To remove corrosion, add a solution of water and baking soda. Use 1lb of baking soda for 1 gallon of water (120g for 1 litre of water). Do not allow any cleaning solution to enter the battery cells. If baking soda is not available, a terminal brush can be used to clean the battery poles. Terminal brushes can be found at most local hardware supplies.

3.8 Storage of batteries

- Plug the charger in when the car is in storage, the charger automatically maintenance charge the batteries.
- Store in a cool, dry location, protected from elements that can damage batteries.
- Disconnect from equipment to eliminate potential electric loads that may discharge the battery.
- Batteries gradually self-discharge during storage. Monitor the specific gravity or voltage every 4-6 weeks. Stored batteries should be given a boost charge when they are at 70% state of charge (SOC) or less.
- When batteries are taken out of storage, recharge before use.

3.8.1 Storage in hot environments (HIGHER THAN 90°F (32°C))

Avoid direct exposure to heat sources, if possible, during storage. Batteries self-discharge faster in high temperatures. If batteries are stored during hot, summer months, monitor the specific gravity or voltage more frequently (approximately every 2-4 weeks).

3.8.2 Storage in cold environments (LESS THAN 32°F (0°C))

Avoid locations where freezing temperatures are expected during storage if possible. Batteries can freeze in cold temperatures if they are not fully charged. If batteries

are stored during cold periods, it is critical that they are kept fully charged. Never charge a frozen battery.

3.8.3 Water supplies

Water supplies must be drained and stored in an empty state if they will be exposed to freezing temperatures. Failure to do so can cause permanent damage to the watering supply.

3.8.4 Watering system

If the vehicle is taken out of service or put into storage for a period of 6 weeks or longer, the HydroLink™ Watering System will require seasonal maintenance. No special steps need to be taken for winterization of a HydroLink™ Watering System that is installed on the batteries; however, the following steps need to be followed when bringing the vehicle back into service:

1. After the batteries have been fully charged/equalized, check the HydroLink™ water level indicator on each battery and refill water if needed.
2. Return the vehicle to its regular service.
3. Restart the vehicle's regular watering schedule (waiting at least 1 week until next watering).

3.9 General information about Trojan® batteries

- A new battery will not deliver its full rated capacity. This is normal and should be expected as the battery needs to be 'worked up' over time.
- Trojan® batteries take between 50-100 cycles to 'work up' before providing full peak capacity.
- When operating batteries at temperatures below 80°F (27°C), they will deliver less than the rated capacity. For example at 0°F (-18°C), batteries will deliver 50% of its capacity and at 80°F (27°C) at battery will deliver 100% of its capacity.
- When operating batteries at temperatures above 80°F (27°C), they will deliver more than the rated capacity, but the life of the batteries will be reduced.

The life time of a battery can be difficult to predict as, among other things, it varies with charging cycles, frequency of usage and level of maintenance.

For further information regarding Trojan® batteries, please refer to Trojan® Battery's official website: www.TrojanBattery.com

For further information regarding the HydroLink™ Watering system with Snake™ Tubing, please refer to Trojan® Battery's official website: www.TrojanBattery.com

4. Operations

4.1 Overview

The Vehicle below is shown with all possible equipment, variation will occur depending on models.

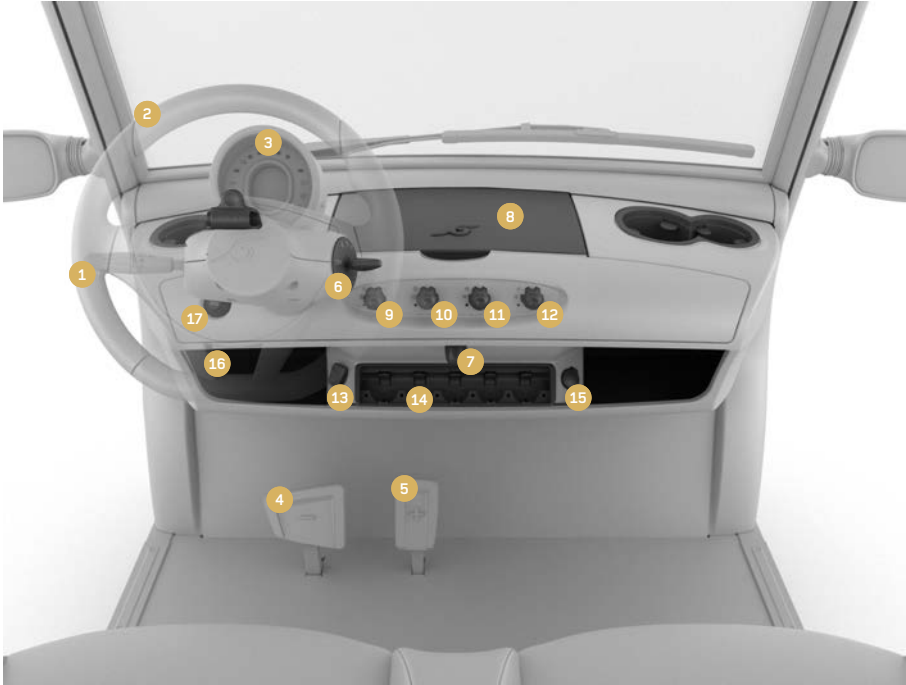

Fig. 4.1

- | | |
|-----------------------|-----------------------------|
| 1. Indicator stalk | 10. Wiper and washer switch |
| 2. Steering wheel | 11. Interior light switch |
| 3. Instrument cluster | 12. Refrigerator |
| 4. Brake pedal | 13. Charger plug with LED |
| 5. Accelerator pedal | 14. Ball holder |
| 6. Ignition switch | 15. USB output |
| 7. Speed switch | 16. Bonnet switch |
| 8. Refrigerator unit | 17. Hazard light switch |
| 9. Heated windscreen | |

4.2.1 Overview Golf car



1. Front wheel
2. Front bonnet
3. Wiper system
4. Rear view mirror
5. Indicator light
6. Headlight
7. Arm-rest

Fig. 4.2



1. Golf bag holder
2. Utility box
3. Rear mudguard
4. Load area
5. Taillights

Fig. 4.3

4.2.2 Overview Monaco



Fig. 4.4

1. Heated windscreen
2. Position light
3. Turn signal light
4. Head light
5. Side view mirror
6. Front mudguard
7. Rear wheel protector
8. 3-point seat belt



Fig. 4.5

1. Tail light
2. Rear reflektor
3. Rear license plate bracket and light
4. Rear mudguard

4.2.3 Overview Via



Fig. 4.6

1. Heated windscreen
2. Turn signal light
3. Head light
4. Amber reflector
5. Side view mirror
6. 3-point seat belt
7. Rear wheel protector



Fig. 4.7

1. Rear reflektor
2. Tail light
3. Rear license plate bracket
4. Rear mudguard

4.2.3 Overview 2+2 edition



Fig. 4,8

1. Umbrella holder
2. Seat back
3. 2-point seat belt
4. Floor board
5. Handrail
6. Golf bag attachment



Fig. 4,9

1. Storage area
2. License plate area with light:
(only standard on Monaco and Via)

4.3 Speed switch (Optional)



Fig. 4.10

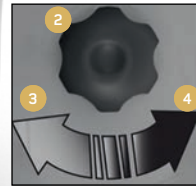

Fig. 4.11



Fig. 4.12



Fig. 4.13

Speed switch functions:

The Garia can be equipped with a speed switch (2) to change between Garia ECO mode (3) to Garia SPORT mode (4), this makes driving in different environments more convenient, since the car accelerates softer and reaches a speed of 16 mph / 25km/h. Change the switch to SPORT mode and the car can reach a speed of 25mph / 40km/h and the car will accelerate faster.

The speed switch position is in the cluster (1) in the lower section of the display, where the text ECO is stationary when the switch is turned left in ECO mode (3) and the text SPORT (4) will be stationary when the switch is turned right in SPORT mode.

4.4 Instrument cluster notifications

4.4.1 Critical battery level



Fig. 4.14

Critical battery level: This appears in cluster when the car has a minimum range left and can only drive in limp mode at 4 Mph / 6 Kp/h. The car urgently requires charging.

4.4.2 Currently no messages



Fig. 4.15

When pressing the right button on the cluster it is possible to review all active messages.

4.4.3 Do not turn vehicle off for 2 min



Fig. 4.16

This message is important to respect, the vehicles requires a “cool down” period of 2 minutes, due to seriously heavy use. After two minutes the vehicle will return to normal operation. The reason for this function is to avoid overloading of important electrical components in the drive system.

4.4.4 Reduced power



Fig. 4.17

Reduce speed for a short period of time and the vehicle will return to normal operation.

4.4.5 Service due



Fig. 4.18

The service due notification will appear when the vehicle has reached the milage or hour limit. Please contact the nearest Garia dealership to get the service carried out accordingly.

4.4.6 Battery discharge indicator



Fig. 4.19

Icon	Led's	State of charge in percent %	
		80 %	100 %
		60 %	80 %
		40 %	60 %
		20 %	40 %
		5 %	20 %
		1 %	5 %

4.5 Ignition switch



Fig. 4.20

Ignition switch functions:

OFF: Most electrical applications are disabled. The refrigerator will function for an additional two hours, if activated whilst the ignition switch is turned to "R,N,F". The interior light and the USB plug will still be functioning. The key can be removed in this position.

If the vehicle is equipped with a cabine heater, then when the key is in the OFF position the fan will still be able to rotate.

R: Reverse. When the accelerator pedal is engaged, the parking brake releases automatically. The vehicle reverses. All electrical functions are in function (affecting battery power).

N: Neutral. The parking brake is engaged when the vehicle comes to a full stop. The vehicle can be temporarily parked, all electrical applications are in function (affecting battery power).

F: Forward, when the accelerator pedal is engaged, the parking brake releases automatically. The vehicle drives forward. All electrical functions are in function. (affecting battery power).

⚠ WARNING

Never push the accelerator pedal when turning the ignition key. The vehicle may move suddenly if not operated correctly.

4.6 Main power switch

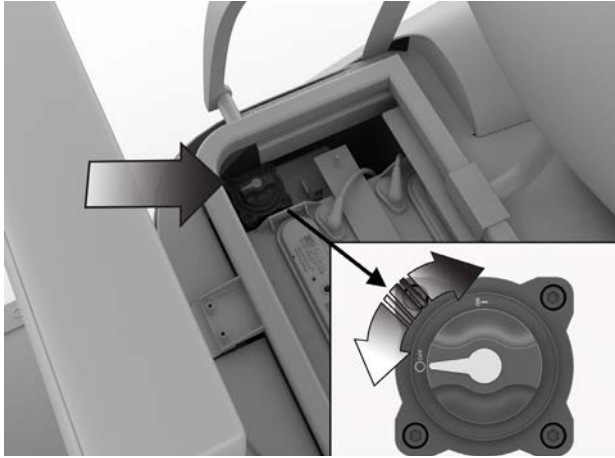

Fig. 4.21

The main power switch is located on the right side of the battery compartment. The switch disables all electrical functions except the automatic parking brake, the ability to charge the vehicle and the back-up power for the instrument cluster unit. When storing the vehicle for longer periods of time, it is recommended that the main power is switched off, in order to experience as little discharging as possible. When servicing or repairing the vehicle (especially the electrical system) always turn main power switch to "OFF".

IMPORTANT NOTE

NEVER LEAVE THE VEHICLE IN THE TOW FUNCTION THIS WILL DRAIN THE BATTERIES AND PERMANENTLY DAMAGE THE BATTERIES.

⚠ WARNING

Serious injuries can occur when working on the electrical system, if the main power switch is turned to "ON". Always turn main power switch "OFF" before working on the electrical system of the vehicle.

4.7 Parking brake

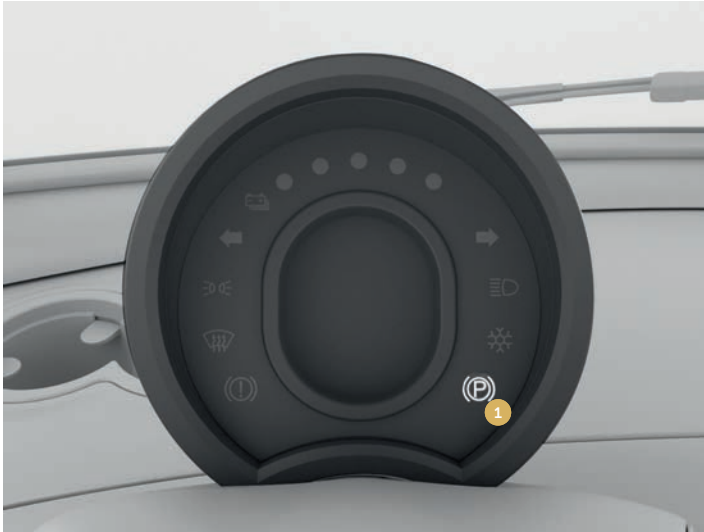

Fig. 4.23

This vehicle is equipped with an automatic parking brake system. When the vehicle comes to a halt, the automatic parking brake will engage automatically after a short delay (2-3 seconds). Until the parking brake is activated, an applied motor brake will keep the vehicle steady until the parking brake is activated. When the car starts moving in response to the accelerator pedal, the parking brake will release automatically. The automatic parking brake can be switched off for towing or repairing needs, however, note that this also disables most electrical functions on the vehicle.

When the vehicle is not driving, the **1** parking brake symbol appears in the instrument cluster, unless if the vehicle power has been turned off by either the ignition or main power switch. The parking brake will still be activated when vehicle power is turned off, although this does not appear in the instrument cluster.

If the parking brake is not functioning as described above, ensure that a qualified repair shop performs a parking brake check. Garia recommends that service is provided by an Authorized Garia Service Dealer.

4.8 Driving, accelerating

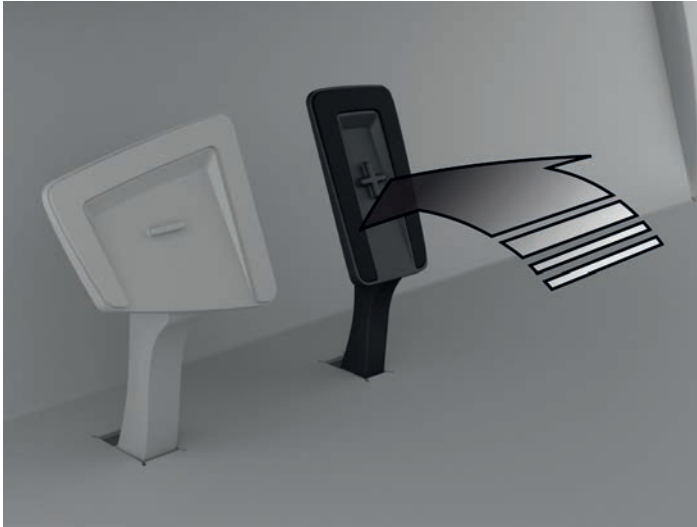

Fig. 4.24

1. Turn Main power switch "ON"
2. Push the brake pedal and turn the ignition key to "N" and following "F" for driving forward (or "R" for reversing,)
3. Make sure that no people or obstacles are in the risk of being injured or damaged by the vehicle. Push the accelerator pedal very gently and the vehicle will start to move. Always accelerate carefully.

⚠ CAUTION

Never bring vehicle to a halt while using the accelerator. Always use brakes to prevent the vehicle from moving.

NOTE

When accelerator pedal is engaged, the parking brake will release automatically.

4.9 Stopping, Braking



Fig. 4.25

To brake or stop the vehicle, push the brake pedal carefully. The vehicle will gently come to a halt. When the vehicle has come to a full stop, the automatic parking brake will engage. The vehicle will not move until the accelerator pedal is engaged. If an emergency occurs, the brakes are designed to handle an emergency braking incident. However, after any emergency braking incident, carry out a brake maintenance check. Please consult a qualified repair shop. Garia recommends that maintenance is provided by an Authorized Garia Service Dealer.

⚠ WARNING

Any damage or malfunction on the braking system can result in severe injury or death. Always make sure that the brakes are fully functioning.

4.10 Rough terrain driving

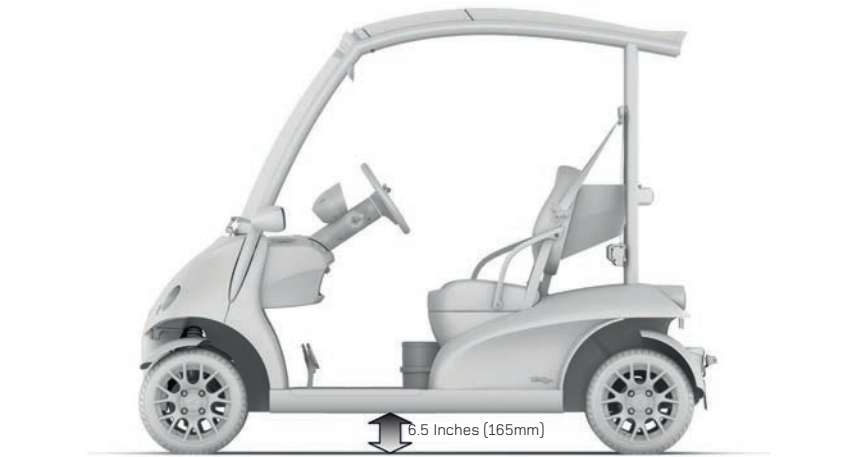

Fig. 4.26

Always make sure that the greatest precautions are taken when driving in rough terrains. The vehicle's ground clearance is 6.5 inches (approx. 165 mm). Always drive slowly and always be ready to stop. Rough terrain driving can cause situations that are damaging to the vehicle, therefore always drive very cautiously. Avoid driving in hilly areas and at tilted angles. The weight distribution of the vehicle can cause it to tip unexpectedly when placing the vehicle at excessive tilted angles. The vehicle is not constructed for rough terrain use, and this should be avoided as far as possible.

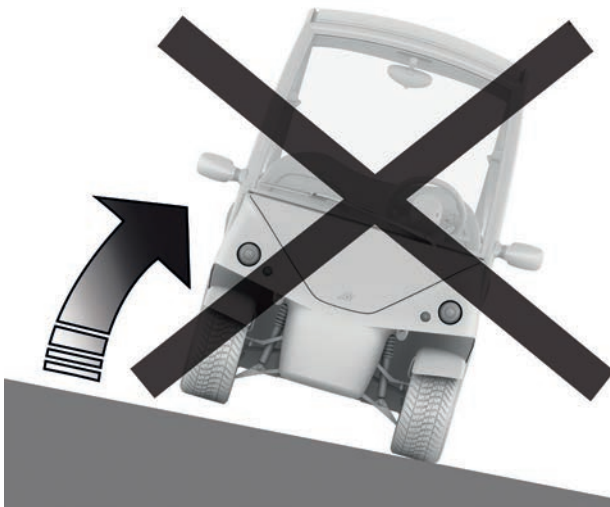

Fig. 4.23

4.11 Hill hold and roll back

The Garia vehicle features a hill hold function which keeps the car at steady speeds when starting and stopping on a slope.

When stopping, the motor will keep the car steady for two (2-3) seconds before the parking brake engages.

If the ignition switch is not turned off, the CAR will remember the amount of torque added when stopping and apply the same amount of torque when starting again to ensure a smooth start and a limited roll back.

Should motor stall appear, the parking brake will engage immediately and the controller will need to be reset with the key switch to "OFF", following to "N" and finally to "F" to start driving (or "R" for reversing).

4.12 Emergency braking

If the key switch is turned into the "OFF" position when the vehicle is moving, motor braking will stop the vehicle slowly. This type of braking can cause personal injury. The parking brake will be engaged when the vehicle has come to a full stop.

Note: This type of braking is for **emergency use only**, if the service brake should fail. It can potentially cause personal injuries or damage to the drive train or tires of the vehicle.

After any emergency braking incident, please contact a qualified repair shop for a brake safety and function check. It is recommended that maintenance is provided by an Authorized Garia Service Dealer.

WARNING

Risk of personal injury!

Brake lights will not come on when performing emergency or motor braking. Only perform this type of braking without closely-following traffic and only in emergency situations.

Any damage to or malfunction of the braking system can result in severe injury or death. Always make sure that the brakes are fully functioning.

4.13 Motor braking

The Garia vehicle is equipped with a motor brake function, that allows the user to brake and stop the vehicle without activating the service brake. It is recommended only to use the motor braking function in controlled emergency braking situations.

How to use the motor brake when driving forward:

- Release accelerator pedal.
- Turn key switch to "R".
- Push accelerator pedal.
- Depending on how much the accelerator pedal is pushed, the motor brakes accordingly.
- Vehicle comes to a full stop.
- For reversing, release and push accelerator pedal again.

If the situation occurs when vehicle is reversing, follow the above mentioned steps, only by turning the key switch to "F" instead of "R".

4.14 Braking with parking brake

If the parking brake should engage during driving at higher speeds than 6 mph (10 km/h) please contact a qualified repair shop for a parking brake safety and function check. Parking brake performance degradation can occur if it has been subject to unintended use. It is recommended that maintenance is provided by an Authorized Garia Service Dealer.

WARNING

Risk of personal injury! This tool is for emergency braking only.

Brake lights will not come on when performing emergency or motor braking. Only perform this type of braking without closely-following traffic and only in emergency situations.

Any damage to or malfunction of the braking system can result in severe injury or death. Always make sure that the brakes are fully functioning.

5. Vehicle equipment

5.1 Dashboard overview

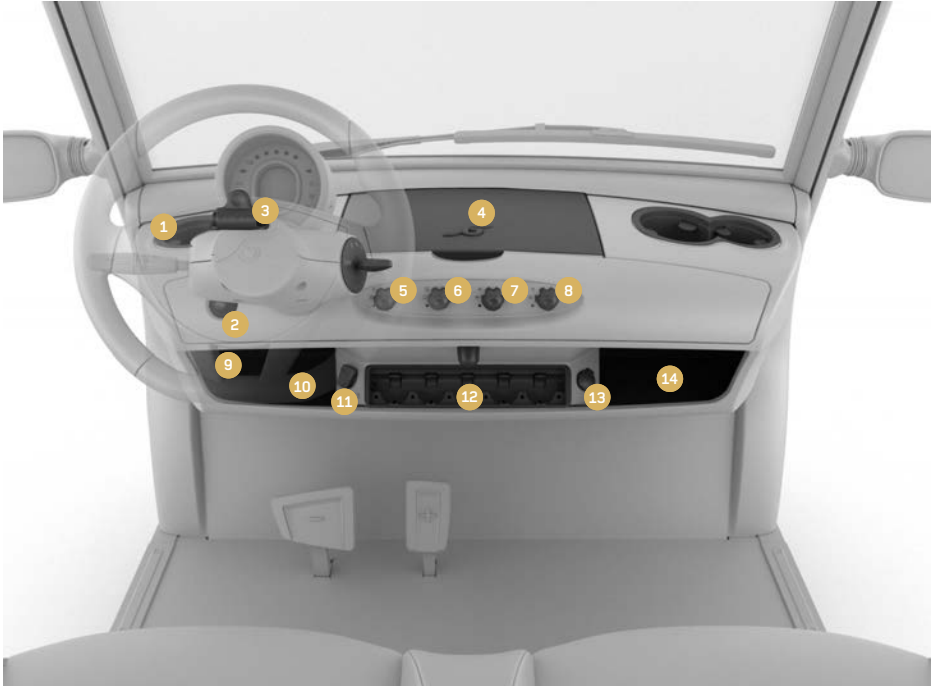

Fig. 5.1

1. Cup holders, two on each side
2. Hazard light
3. Scorecard holder
4. Dashboard lid for storage box and refrigerator
5. Heated windscreen
6. Windscreen wiper/washer
7. Interior light
8. Refrigerator unit
9. Bonnet opener button
10. Left storage compartment
11. Charger plug
12. Golf ball and tee holder
13. USB outlet
14. Right storage compartment

5.2 Seats



Fig. 5.2

5.2.2 Below the seats:

The battery compartment is located below the seats. This contains the main power switch, the towing switch, the batteries, the brake fluid container and the VIN (vehicle identification number). For access to the battery compartment, tip the seat as shown in fig. 5.2. Please see chapter 3 for information regarding the batteries.

5.3 Instrument cluster functions and warning lamps

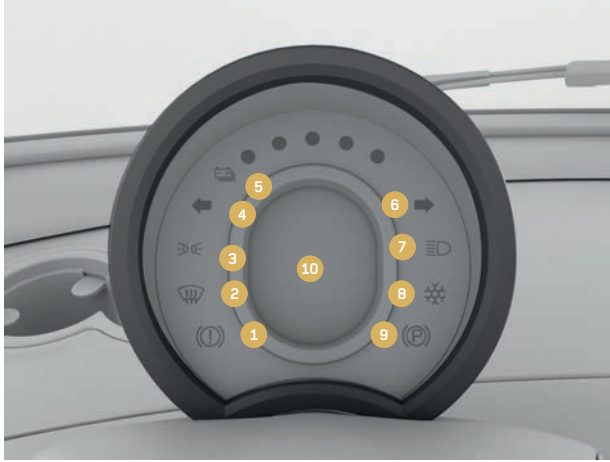

Fig. 5.3

The instrument cluster unit combines all the information about the vehicle that the driver needs for proper operation. If front light are turned on the cluster will automatically dimm the display creating a more comfortable drive.

1. Brake fluid warning level indicator
2. Heated windshield
3. Position light
4. Turn signal left
5. Battery charge indicator
6. Turn signal right
7. High beam
8. Refrigerator
9. Parking brake activated
10. Digital display

5.3.1 Inner cluster explanation



Fig. 5.4

1. Speedometer
2. Odometer, trip counter, operation counter
3. Clock
4. Speed switch position (Optional)

5.3.2 Button on instrument cluster (left)

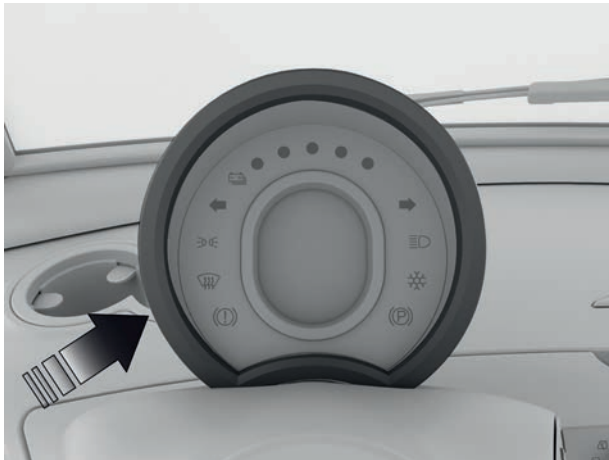

Fig. 5.5

1. Push button to change between overall distance and time as well as trip distance and trip time.
2. Hold button down to reset trip distance and trip time (approx. 3 seconds).

5.3.3 Button on Instrument cluster (right)

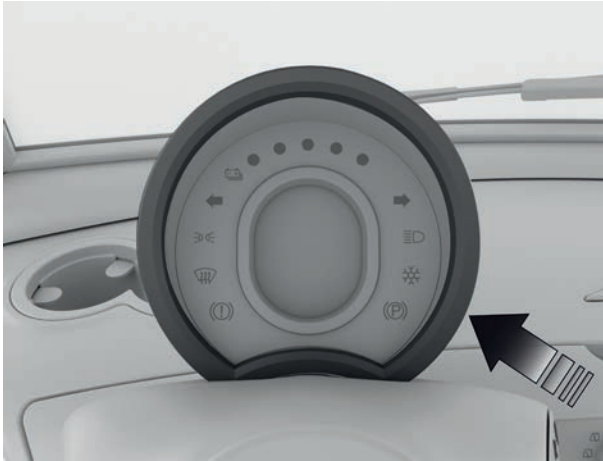

Fig. 5.6

The button on the right side of the instrument cluster adjusts the clock. To adjust, hold down the button on the right side of the instrument cluster.

- Hours will blink. Push repeatedly to set hours.
- Wait for approximately 5 seconds.
- Minutes start blinking. Push repeatedly to set minutes.
- Wait until minutes stop blinking (approx. 5 seconds).
- Clock is set.

5.4 Indicator stalk

Indicator stalk overview:

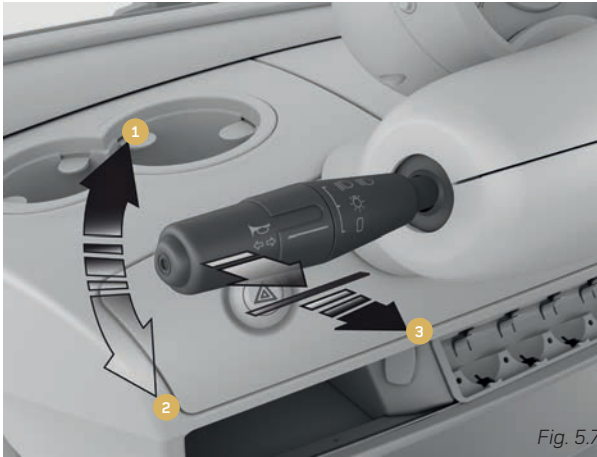

1. Turn signal right
2. Turn signal left
3. High beam on / off (Can only be activated when 4 is in third position)
4. Light off / position light / low beam on (when activated the light in the instrument cluster will automatically dimm)
5. Horn

5.5 Airscoop

5.5.1 Opening and closing the air scoop



Fig. 5.9

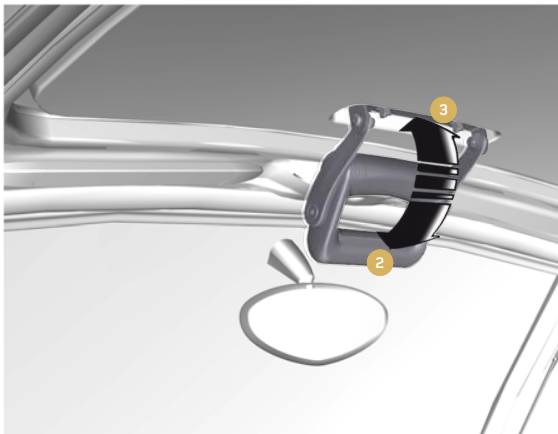

Fig. 5.10

The Garia vehicle is equipped with a air scoop which allows air to reach the passengers while driving. To open the air scoop push ① lever down to unlock the handle and then ② push the handle upward. To ③ close the air scoop, pull the lever downwards, and the air scoop will close.

5.6 Storage room under bonnet



Fig. 5.11



Fig. 5.12

The Garia vehicle is equipped with a storage compartment under the bonnet. To open the bonnet, push the button for the bonnet mechanism on the dashboard. This compartment offers a lockable storage space which enables the user to leave the vehicle without having to remove all loose items from the vehicle. The bonnet can be opened by pushing the button under the dashboard as illustrated in figure 5.12, only when the ignition switch is in “R,N,F” and the main power switch is turned “ON”.

- Do not drive while bonnet is open.
- Do not open bonnet while driving.

5.7 Bin

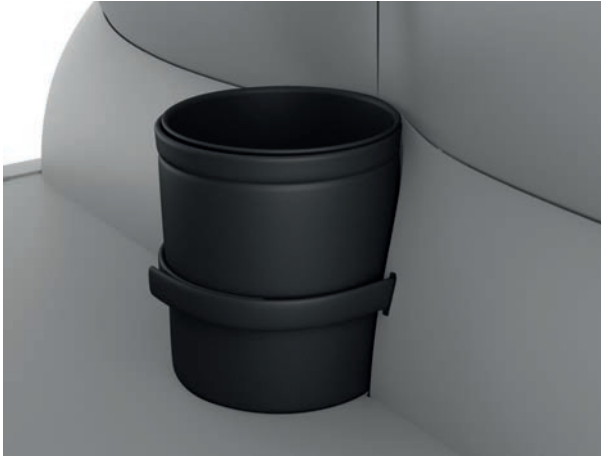

Fig. 5.13

This bin offers the possibility of transporting your or your passenger's preferred beverages.

The bin can also function as a trash can. The plastic insert is removable and the complete bin can be removed by opening the bin strap.

Note: Be careful not to pull out the bin strap.

WARNING

NEVER operate a vehicle under the influence of alcohol and/or drugs. Driving under the influence of alcohol or drugs considerably reduces the ability to concentrate, focus, judge speed and distance and can result in severe personal injury, death or excessive material damage.

Garia strongly discourages the operation of any vehicle while intoxicated by alcohol, drugs or similar.

5.8 Multifunctional rear section

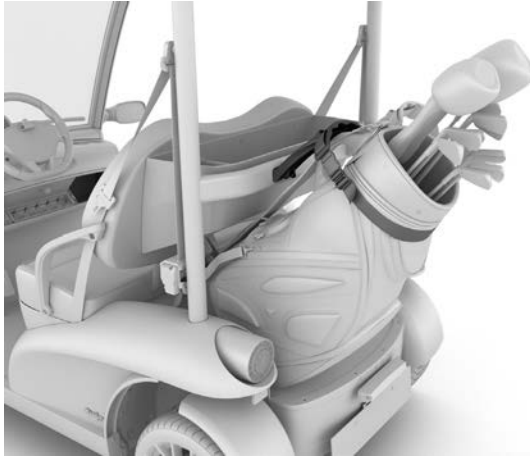

Fig. 5.14

The Garia bagholder system allows convenient transportation of two golf bags with an easy access to golf clubs.
Place golf bags in an angled position and tighten the straps that secure the golf bags during transportation.

⚠ CAUTION

When driven with golf bags be aware that the total length of the car is increased and may cause dangerous situations which can cause material damage.

5.9 Adjusting rear view mirror

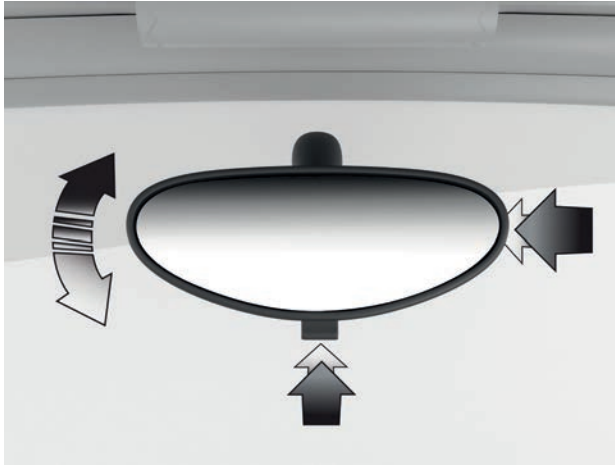

Fig. 5.15

Adjust the rear view mirror to ensure that the view to the rear is as unobstructed as possible. Wrong adjustment can cause dangerous traffic situations and cause accidents resulting in severe personal injury, death or material damage. The mirror has a tip-function for convenience to avoid blinding from behind coming traffic. The anti-blinding function is activated by pushing the lever under the mirror forward. Do not adjust mirrors while driving. This takes focus off the driving and can create dangerous situations.

5.10 Refrigerator and Storage box

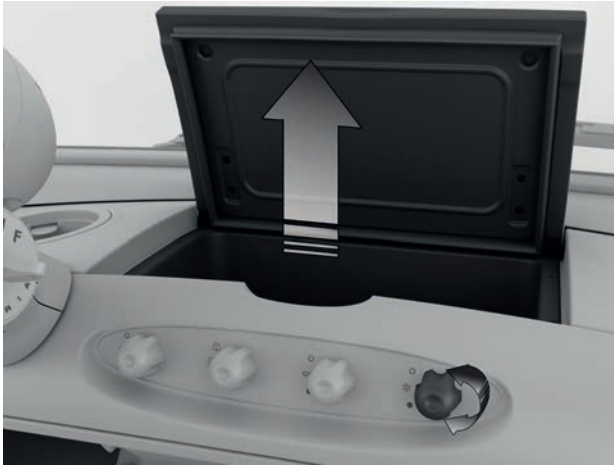

Fig. 5.16

The refrigerator provides cooling for foods and beverages when the vehicle is in operation. When turned on, the refrigerator constantly provides cooling when the vehicle ignition switch is turned to “F”, “N” or “R”.

The refrigerator will continue its cooling function for an additional 2 hours after the ignition switch has been turned “OFF”, if it is not turned off by its respective switch. The refrigerator will stop functioning, if turned off by the switch on the dashboard or if the power is disconnected by the main power switch in the battery compartment.

5.10.1 Energy saving tips

- Allow hot food to cool down before you place it in the refrigerator.
- Do not open the refrigerator more often than necessary.
- Do not leave the lid open for longer than necessary.
- Defrost the refrigerator once a layer of ice forms.

5.10.2 Defrosting the refrigerator

Humidity can form frost in the interior of the refrigerator. This reduces the cooling capacity. Defrost the refrigerator frequently to avoid this.

NOTE

The use of the refrigerator requires battery power and decreases the vehicle range. Avoid using optional extras excessively to avoid stalling while driving if battery power is low.

5.11 Interior light (OPTIONAL / standard on Via and Monaco)

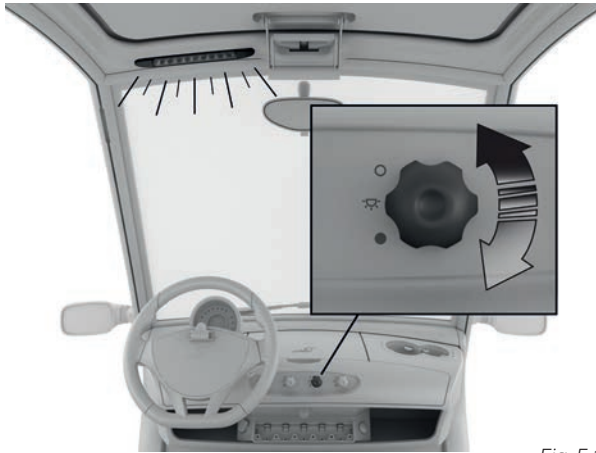

Fig. 5.17

The interior dome light is placed in the headliner between the windshield and air scoop. Turn the switch on the dashboard to activate or deactivate the interior light. Use only when vehicle is not in movement. Avoid drive while interior light is on, it can obstruct the vision of the driver, especially when driving in the dark.

NOTE

The use of the interior dome light requires battery power and decreases the vehicle range. Avoid using optional extras excessively to avoid stalling while driving if battery power is low.

5.12 Windshield wiper/washer (optional / standard on Via and Monaco)

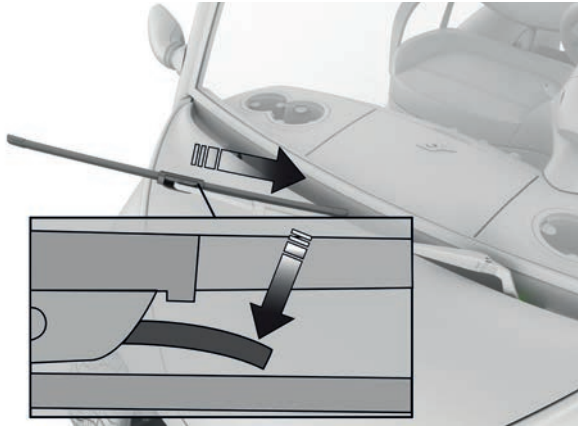

Fig. 5.18



Fig. 5.19

Wiper blade release (Fig.5.18)

Water reservoir/washer windshield fluid (Fig.5.19)

The windshield wiper is activated by the switch on the dashboard. Turn the button one step to activate the wiping function. To activate the windshield washer function, turn and hold another step, release when sufficient washer fluid has been applied to the windshield..

5.13 Heated windscreen (Optional).



Fig. 5.20

When the heated windscreen is turned on an icon in the instrument cluster will appear illustrating that it is activated. The heated windscreen will stay on for approximately 30 minutes. It will shut off by itself unless the ignition key is turned off.

6. Service

6.1 Service Intervals

In order to keep your Garia vehicle in the best condition, Garia has prepared a specially designed service program, to ensure that the vehicle constantly lives up to the highest standards.

The following service intervals have to be met to uphold the warranty.

- 12 months / 360 hours service
- 24 months / 720 hours service
- 36 Months / 1080 hours service

Besides the above mentioned service intervals, additional daily, weekly and monthly checks are required, which can be performed by the owner of the vehicle to uphold the quality and functionality of the vehicle. The following pages state how to ensure the proper maintenance of your Garia.

If the vehicle is malfunctioning in any way not specified in this user's manual, please consult a qualified repair shop. Garia recommends that any work is provided by an Authorized Garia Service Dealer.

The attached quick guide and service book contains the space for service stamps and service and repair remarks. Always be sure to remind your local dealer/repair shop to apply stamps and comments after each service interval.

6.2 Service symbol in Instrument cluster

This vehicle is equipped with a memory function that reminds the user to service the vehicle regularly. This symbol will be reset after each service by an Authorized Garia Service Dealer and reappears once the next service is due. Always make sure that the vehicle is maintained according to the service indicator in the instrument cluster. Failure to follow this will void all applicable warranties.

6.3 Service Actions

C = Check	CA = Check & Adjust	R = Replace	S = Service	CL = Clean & Lubricate	L = Lubricate			
Months		12	24	36	48	60	72	84
Hours		360	720	1080	1440	1800	2160	2520
CHECK:								
Tire pressure	CA	CA	CA	CA	CA	CA	CA	CA
Visual inspection of tires & rims	C	C	C	C	C	C	C	C
Brake fluid level	C/S	R	C/S	R	C/S	R	C/S	C/S
Battery mounting & liquid state	S	S	S	S	S	S	S	S
Wires, battery cables & various connectors	CL	CL	CL	CL	CL	CL	CL	CL
Steering for free play	S	S	S	S	S	S	S	S
Inspection of shocks, springs, cuffs	C	C	C	C	C	C	C	C
Inspection of front & rear lights	C	C	C	C	C	C	C	C
Headlight adjustment	CA	CA	CA	CA	CA	CA	CA	CA
Washer nozzle position (if present)	CA	CA	CA	CA	CA	CA	CA	CA
Wheel bearings for play & sound	S	S	S	S	S	S	S	S
Toe-in alignment	CA	CA	CA	CA	CA	CA	CA	CA
Differential oil	S/CA	S/CA	R	S/CA	S/CA	R	S/CA	S/CA
Windscreen washer fluid	C	C	C	C	C	C	C	C
Front brakes	S/CL	S/CL	S/CL	S/CL	S/CL	S/CL	S/CL	S/CL
Rear brakes (Drum brakes)	S/CL	S/CL	S/CL	S/CL	S/CL	S/CL	S/CL	S/CL
Discharge test	S	S	S	S	S	S	S	S
Heated windshield (if present)	C	C	C	C	C	C	C	C
Windshield for cracks & damages	C	C	C	C	C	C	C	C
Refrigerator (if present)	C	C	C	C	C	C	C	C
Lower A-arm	C/S	C/S	C/S	C/S	C/S	C/S	C/S	C/S
Upper A-arm	C/S	C/S	C/S	C/S	C/S	C/S	C/S	C/S
Rear trailing links	C	C	C	C	C	C	C	C
Rear Panhard rod	C	C	C	C	C	C	C	C
Transmission	C	C	C	C	C	C	C	C
A/C motor	C	C	C	C	C	C	C	C
Controller	C	C	C	C	C	C	C	C
Throttle box	CA	C	CA	C	CA	C	CA	CA
Seat belts (if present)	C	C	C	C	C	C	C	C
Interior light (if present)	C	C	C	C	C	C	C	C
Seat adjustment (if present)	C	C	C	C	C	C	C	C
Card holder	C	C	C	C	C	C	C	C
Side mirrors (if present)	C	C	C	C	C	C	C	C
Licence plate light (if present)	C	C	C	C	C	C	C	C
Instrument cluster (service reset/ function)	CA	CA	CA	CA	CA	CA	CA	CA
Center console buttons (if present)	C	C	C	C	C	C	C	C

6.4 User Self-service

Following the guidelines below, the user of the vehicle can constantly make sure that the Garia vehicle is in the best and safest working condition.

Garia recommends to follow this schedule accurately and consult a qualified repair-shop if any part of the vehicle is not functioning correctly and cannot be replaced by the user.

C = Check CR = Check and replace (if needed)			
CHECK:	Daily	Weekly	Monthly
Tires and rims. (visual inspection of cracks, debris and damages)	CR		C
General vehicle conditions (defects and damages)	C		
Functionalty of the lights (bulbs, adjustment etc).	CR		C
Brake pedal travel	C		
Wiper function, windshield washer fluid, wiper blade.		CR	C
Batteries, battery shoes, cable assembly, acid etc (visual inspection)		CR	C
Tire pressure and tire wear	C		
Functionality of the reverse warning indicator (Except Monaco)	C		
Brake fluid level			C

7.1 Replacing light bulbs

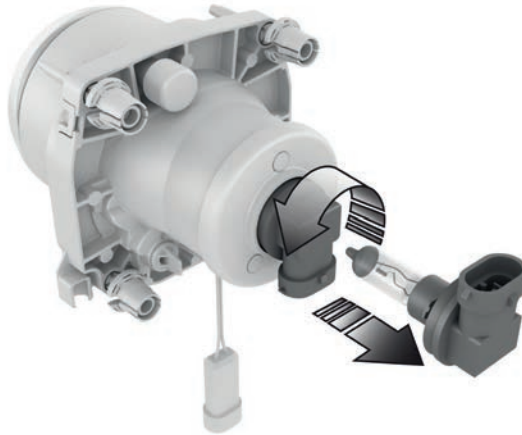

Fig. 7.1

To replace the bulb of the headlight, access the socket from within the front storage compartment. Disconnect the cable plug for the bulb and turn the bulb socket $\frac{1}{4}$ of a turn counter clockwise. The bulb will release from the lamp fitting. Turn the bulb an additional $\frac{1}{4}$ of a turn, so the cable fitting is facing upwards. The bulb can be removed from the lamp fitting. Exchange the bulb with a new, suitable for the original type for the vehicle and follow the guidance above in reverse. (Bulb type H9, 65W on Via and Golf Car / Bulb type on Monaco is H7, 55W)

⚠ WARNING

Hot bulbs can cause severe burns. Always disconnect cables and do not touch the bulb until it has cooled off. Never touch a lighted bulb.

NOTE

Never touch the glass of a bulb. Touching the glass will shorten the life of a bulb significantly. Use a glove or a cloth when handling a light bulb.

7.2 Replacing the bulb for the front position light



Fig. 7.2

1. To replace the 12V bulb of the front position light, access the socket from within the front storage compartment.
 2. Remove the insulation of the socket and then pull the socket out of the lamp fitting.
 3. Replace the lamp, by pulling out the W5W bulb and replacing it with a new.
- Then insert the socket into the lamp fitting and ensure that the insulation prevents moisture, dust or sand from entering the lamp

7.2.1 Replacing bulbs of the front and rear lights

The front position light on Monaco and the front turn signal light on VIA and rear light system is a closed circuit, and LEDs cannot be replaced separately. Please consult a qualified repair shop. Garia recommends that all maintenance and repairs are provided by an Authorized Garia Service Dealer.

NOTE

In order to provide the required legal luminous intensity, all LEDs must function properly. Always replace lights, if any LED is not functioning correctly.

7.3 Jack points

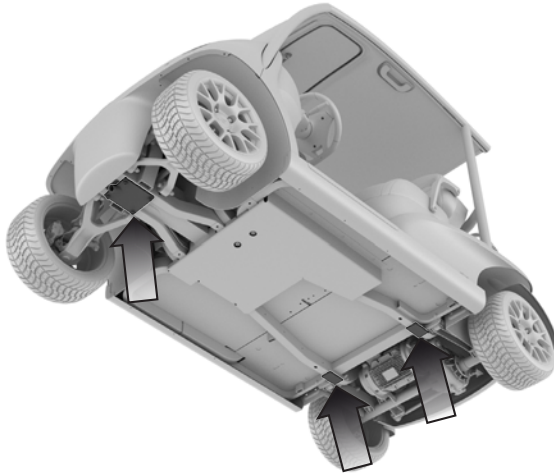

Fig. 7.3

When raising the vehicle for changing wheels or other work on the underside of the vehicle, the vehicle must be raised on one of the illustrated jack points. Only use the jack-points and to prevent any damage to the vehicle.

Never work under a vehicle that is only supported by a jack.

Only lift vehicle on a firm, stable and level surface.

Use jack stands and check that vehicle is stable and secure to work under.

Chocks should be placed at the wheels not being raised to prevent vehicle from rolling.

Work with extreme caution, since lifting causes great instability in the vehicle.

⚠ WARNING

To reduce the possibility of severe injury or death from a vehicle falling from a jack or a jack stand, ensure that the following precautions are taken.

- Vehicle is placed on a firm, stable and level surface
- No work is performed unless the vehicle is secured by jack stands.
- Chocks are in front of and behind wheels that are not being raised.
- Work with extreme caution, since a lifted vehicle can be very unstable.

7.4 Changing a wheel



Fig. 7.4

When changing a wheel, always ensure that the vehicle is raised on an even surface enabling it to be raised properly. Only use the marked jack-points to prevent any damage to the vehicle.

- Place chocks around all wheels not being lifted to prevent vehicle from moving.
- Loosen the wheel nuts slightly (1/4 of a turn) before raising the vehicle (**NEVER completely unscrew ANY of the bolts when the vehicle has not been raised.**)
- Always make sure that bolts are cross-loosened and cross-tightened as illustrated above.
- Raise the car and remove all bolts.
- The wheel can be removed and another can be mounted.
- Always use the same size and type of wheel for all 4 wheels on the vehicle.
- Use only original model-specific Garia standard or optional wheels to ensure safe driving conditions and correct dimensions for the vehicle.

- When mounting a new wheel, reverse the steps mentioned above and tighten bolts.
- Tighten the wheel bolts with a tightening torque of 89 ft-lbs (120 Nm).
- Check tightening of wheel bolts after one week of driving, retighten if necessary.

7.5 Cleaning the vehicle

When cleaning your Garia vehicle, the following procedure ensures the best possible result to attain a look close to the vehicle's appearance when new. Most importantly, always make sure to turn the main power switch to "OFF" before working on an electric vehicle. The combination of water and high voltage is extremely dangerous and could be fatal.

Do not clean any part of the vehicle with a high-pressure cleaner.

7.5.1 Exterior

Water the vehicle with running water (e.g. a garden hose) to wet the vehicle and to wash away larger pieces of dirt, dust or similar. Avoid as much as possible getting water on the seats and dashboard, especially around the area of electronic switches and appliances. Although durable for small amounts of water, the interior can be damaged when exposed to large quantities of water. Apply water mixed with automotive shampoo (please follow manufacturer's instructions regarding mixture proportions and other instructions). Use a clean soft sponge or brush specifically for automotive exterior cleaning for applying on vehicle exterior. Wash off shampoo with running water (e.g. a garden hose) and dry vehicle with a chamois for automotive use.

7.5.2 Wheels

When using the same sponge for cleansing rims as exterior, it is strongly recommended that the exterior bodywork is cleaned before cleaning the wheels. If the cleaning is done in reverse, the dust from the wheels can risk permanent damage by scratching the painted surface of the exterior. Wet the rims with running water. Apply rim cleansing solution or automotive shampoo with a clean soft sponge or brush and rinse after a short while with running water.

7.5.3 Rubber flooring

Wet the rubber with running water. Apply rubber cleansing solution or automotive shampoo with a clean soft sponge or brush and rinse after a short while with running water. Dry surface gently with a chamois for automotive use. Allow flooring to dry completely before usage to attain the best result. If the rubber flooring shows discoloration due to wear, tear and extreme weather conditions, it is recommended that an aftermarket rubber shine solution is applied to attain 'close-to-new' looks.

7.5.4 Interior

To clean the interior, use a moist cloth or chamois to wipe the surfaces. For thorough cleaning, use automotive interior cleaning solutions and follow instructions carefully. Avoid using running water or high pressure cleaner for cleaning the interior.

7.5.5 Seats

For cleaning the seats and other parts of the interior of similar fabric, wipe with warm water using a wrung cloth. The water can contain mild detergents, with mixture proportions according to manufacturer's specifications. Do not use running water, high-pressure cleaning, solvents, bleaches, abrasives, synthetic detergents, wax polishes or aerosol sprays. Avoid contact with sharp objects.

7.5.6 Battery maintenance and care

Maintaining batteries properly includes always charging batteries after use, ensuring the correct level of fluid in the batteries as well as general removal of corrosion, dust, dirt and/or similar, apply anti corrosion liquid if needed.

For further information please see chapter 03

WARNING

Watering a battery before charge (or with a low charge level) can lead to boil-over resulting in potential bodily injury and potential damage to the watering system, battery and vehicle.

Ensure that the work area is dry when servicing the vehicle, watering system, battery or battery charger.

WARNING

Risk of electric shock! Always turn Main power switch "OFF" when working with water around an electric vehicle.

Do not clean any part of the vehicle with a pressure cleaner.

7.6 Controlling the brake fluid



Fig. 7.5

The brakes are a vital part when driving a Car. It is of utmost importance to ensure that the brakes are functioning correctly at all times. Controlling the brake fluid level is an indicator showing if the braking system is functioning correctly.

This vehicle is equipped with a brake fluid level warning indicator which is on the instrument cluster. It informs the driver, if the brake fluid level is reaching a level too low for safe braking operation. If the light is lit in this indicator, a check and a refill could be necessary. It is recommended that a check of the brake fluid level is made regularly. The brake fluid container is found under the front seat on the left side of the compartment. Check that the fluid level is above the minimum requirement but still below the maximum requirement. Too much or too little brake fluid can cause permanent damage to the entire braking system, putting your safety at risk.

Always use DOT 4 brake fluid.

If brake fluid levels are correct but the braking system shows irregularities, please consult a qualified repair shop. Garia recommends that all maintenance and repairs are provided by an Authorized Garia Service Dealer.

WARNING

ALWAYS make sure that the braking system is functioning correctly. Malfunctioning brakes can cause **SERIOUS INJURY OR DEATH** to drivers or people near the vehicle.

7.7 Tow switch

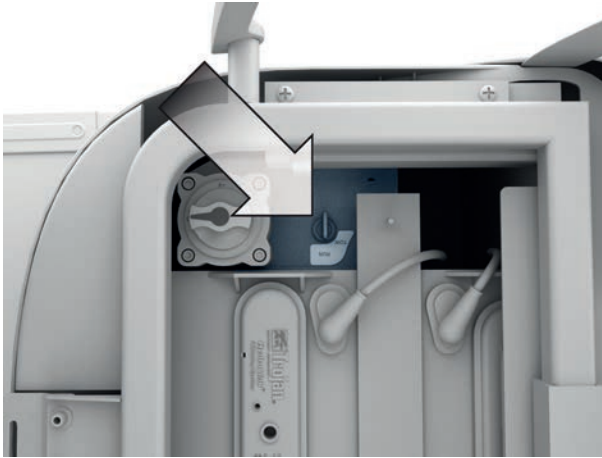

Fig. 7.6

To activate the towing function, the switch in the battery compartment must be engaged. This can only be done by using the additional key which came with the car at its delivery. Please note, this key is not the same as the ignition key. It is recommended that the key is removed from the keyhole whenever the towing function is not activated. Doing this prevents unauthorized removal of the vehicle. To be able to activate the towing function, the ignition switch on the steering column must be turned to the "N"-position. Furthermore it is necessary that the main power switch in the battery compartment is turned to the "ON"-position. Select "TOW" to activate the towing function.

Activating the towing function discharges the battery. Do not store vehicle with towing switch turned to "TOW", since this eventually will discharge the batteries and permanently damage the batteries. Fully discharging the batteries shortens the life of the battery. Activating the towing function disables the ignition information, meaning that the vehicle will not drive.

Always make sure to take the best safety precautions when releasing parking brake. Activating the towing switch disables most electrical appliances in the vehicle.

⚠ WARNING

The vehicle can roll unexpectedly at all times when the parking brake is released, even on level ground. This can cause a severe accident or death.

7.8 Towing without battery power

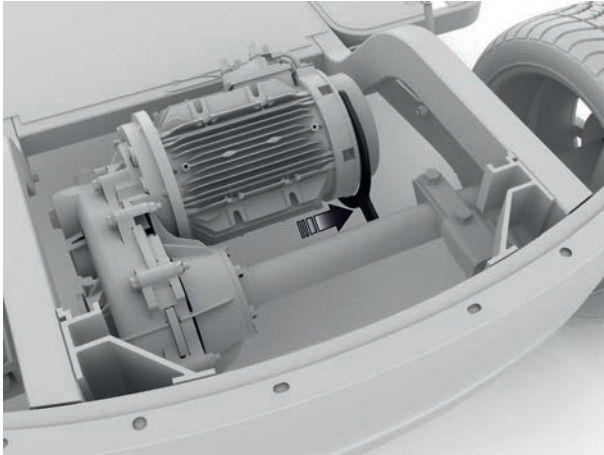

Fig. 7.7

If vehicle batteries are completely discharged or malfunctioning and there is no possibility of activating the towing function through the towing switch, the parking brake can be released by manually engaging the lever on the motor as illustrated above. Push the lever to release the parking brake and the vehicle can be towed.

Access the lever from the underside of the vehicle or by removing the load area floor. Once the towing session has taken place, it is of great importance to activate the parking brake before vehicle is put into service.

Always take the greatest safety precautions when releasing parking brake. If unsure on how release the parking brake manually it is recommended that you contact the nearest Garia dealer or service shop.

⚠ WARNING

The vehicle can roll unexpectedly at all times when parking brake is released, even on level ground. This can cause a severe accident!
Activate automatic parking brake function before vehicle is put into service!

7.9 Towing hook

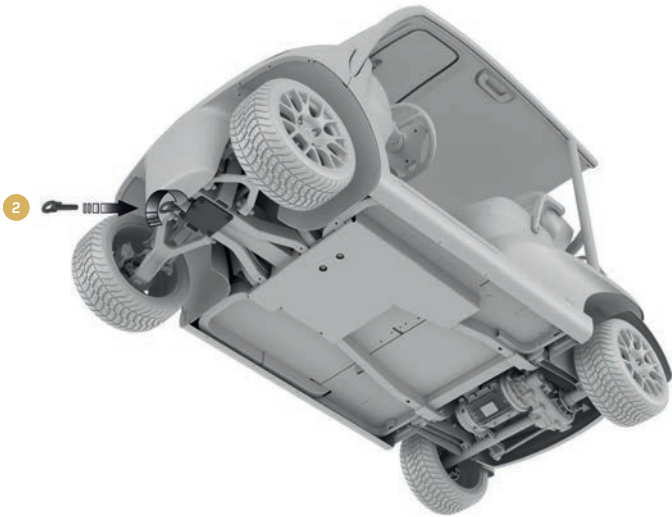

Fig. 7.8

If the vehicle requires to be towed, the towing hook **2** is mounted underneath the front body as illustrated above. (Towing hook is standard equipment on all vehicles)

⚠ WARNING

Use caution when towing a vehicle.

Do not attempt to tow vehicle with any other device than an approved automotive towing rope.

Do not tow vehicle on highways or other public roads not specified for use.

Only tow one vehicle at a time.

The vehicle can roll unexpectedly at all times when parking brake is released, even on level ground. This can cause a severe accident.

Do not exceed 10 mph (16 km/h) while towing.

7.10 Hauling

This Garia vehicle is not constructed for hauling. This includes other vehicles, trailers or other devices. When hauling the vehicle on a trailer use the tie down brackets in the rear. Failure to heed this warning will void all applicable warranties.

7.11 Fuse box location

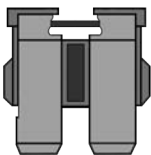

Fig. 7.9

The fuse box is situated as illustrated above. (under the bonnet, passenger side)
If a malfunction in the electrical system occurs, it is recommended to check the fuses.

Always be sure to replace fuses for the same amperes as specified on the following page. Replacing fuses for other amperes than specified can cause malfunctions or break-downs on the electrical system.

It is fairly easy to determine if a fuse is defective/blown, disconnect the fuse from the socket in the fuse box. See illustration below on how to determine if the fuse is defective.



OK

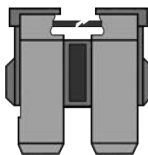

Defective

⚠ CAUTION

Danger of damaging the device!

Only replace fuses for the same amperes as specified in this fuse box lid. Replacing fuses for other amperes or voltages than specified can cause fire or serious damage to the electrical system of the vehicle.

7.11.1 Fuse box layout

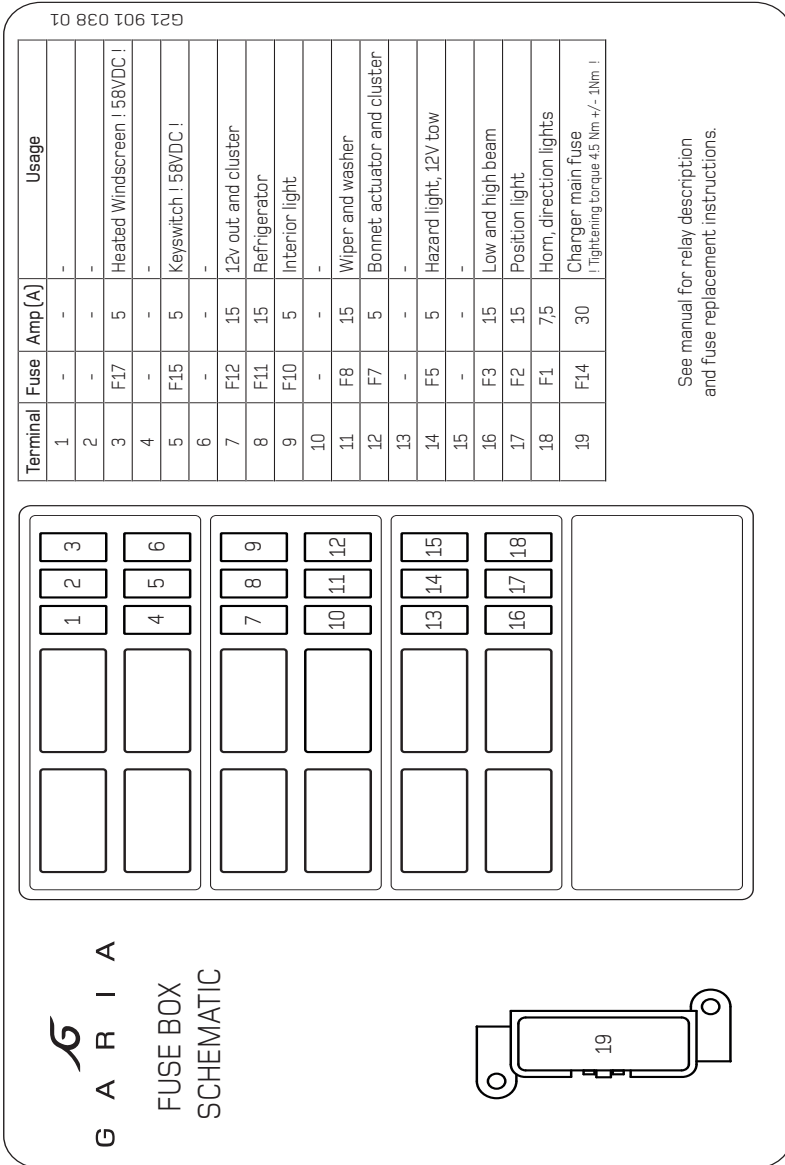

Fig. 7.10

8. Troubleshooting

8.1 The car will not drive.

- Check if Main power switch is "ON" in battery compartment.
- Check if Towing switch is "OFF" in battery compartment.
- Check if Ignition switch is in "F" or "R".
- Check if batteries are charged enough to drive vehicle by looking at the battery indicator in the instrument cluster.
- Reset the vehicle - please see next page for how to reset the vehicle
- If all of the above are confirmed, please consult a qualified repair shop. Preferably an Authorized Garia Service Dealer.

8.2 The vehicle will only drive at a very slow speed.

- Are the batteries properly charged? If vehicle voltage is below 37,5V, the vehicle can have switched to LOS-mode (limited operation strategy). It is a safety program that allows the vehicle to drive at very low speeds only. Fully charge batteries to switch off LOS mode.
- Reset the vehicle - please see next page for how to reset the vehicle
- Please consult a qualified repair shop. Preferably an Authorized Garia Service Dealer.

8.3 The vehicle has a lower range than usual.

- One or more batteries can be malfunctioning. Batteries will typically experience lower capacity after many cycles of charging.
- Allow batteries to fully charge and check for correct water levels.
- If this does not help, please consult a qualified repair shop. Preferably an Authorized Garia Service Dealer.

8.4 The Charger will not charge the batteries.

- Check that the power inlet is supplying power to the charger.
- Check that the charger LED is indicating that the batteries are charging.
- Charger can be overheating in hot weather conditions. Allow charger to cool or engage charging in a cooler environment
- Reconnect the charger plug
- If this does not help, please consult a qualified repair shop. Preferably an Authorized Garia Service Dealer.

8.5 What to do with a completely flat battery.

- Engage a full charging cycle of the battery
- If this does not help, please consult a qualified repair shop. Preferably an Authorized Garia Service Dealer.

8.6 How to reset the vehicle.

- If the vehicle shows any electrical errors, resetting the electric system could provide aid for solving this. Resetting the vehicle is done by turning the Main power switch "OFF" and turning it "ON" again 30 seconds after.
- If that does not help apply the charger cable for 1 hour, when done cycle between "R,N,F" and back to off. (This will reset the DBI on the controller)
- If this does not help, please consult a qualified repair shop. Preferably an Authorized Garia Service Dealer.

8.7 The lights do not work

- Check the fuse. If fuse is not intact, replace with a new.
- Check if bulbs are functioning correctly. If not, replace with a new.
- If none of the above prove helpful, please consult a qualified repair shop. Preferably an Authorized Garia Service Dealer.

8.8 The refrigerator does not work

- Turn ignition on (turn to 'N'), and activate the refrigerator on the 'refrigerator' button on the dashboard. The refrigerator symbol in the instrument cluster will be lit if power is on and ignition switch is not turned to 'Off'.
- Check the fuse. If fuse is not intact, replace with a new.
- If none of the above prove helpful, please consult a qualified repair shop. Preferably an Authorized Garia Service Dealer.

8.9 The refrigerator stops cooling when parked (less than 2 hours)

- Main power switch must be on.
- Check the fuse. If fuse is not intact, replace with a new.
- If none of the above prove helpful, please consult a qualified repair shop. Preferably an Authorized Garia Service Dealer.

8.10 The brake pedal is soft, or goes down without resistance.

- Do not drive vehicle, brakes can be malfunctioning. Please consult a qualified repair shop. Preferably an Authorized Garia Service Dealer.

8.11 The vehicle vibrates in the steering wheel

- Please check tire pressure, apply 32 Psi / 2,2 bar in each tire as recommended in this manual.

9. Vehicle Dimensions

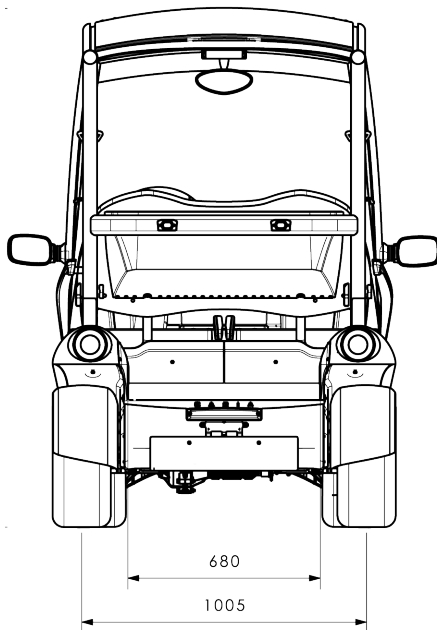
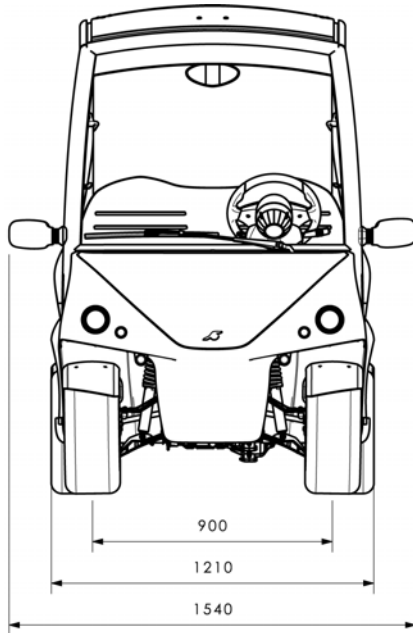

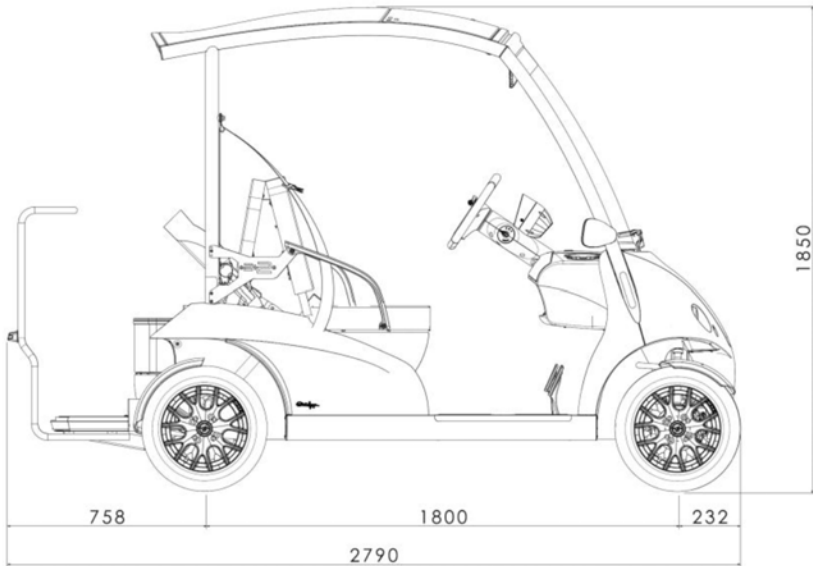
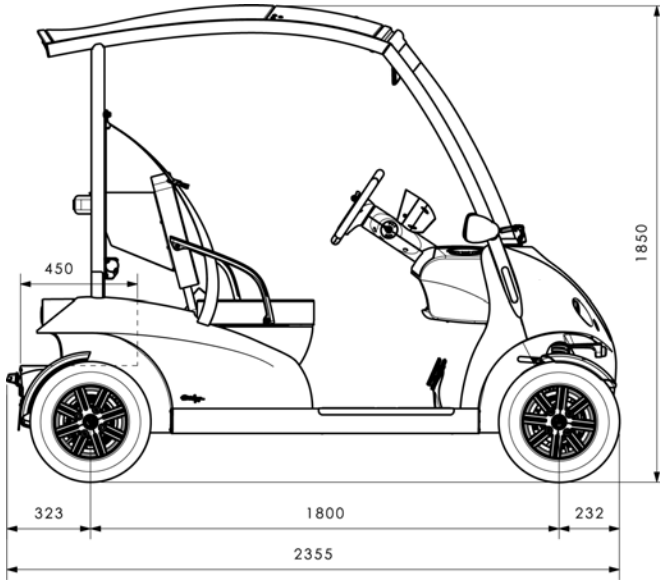

09 VEHICLE TECHNICAL SPECIFICATIONS

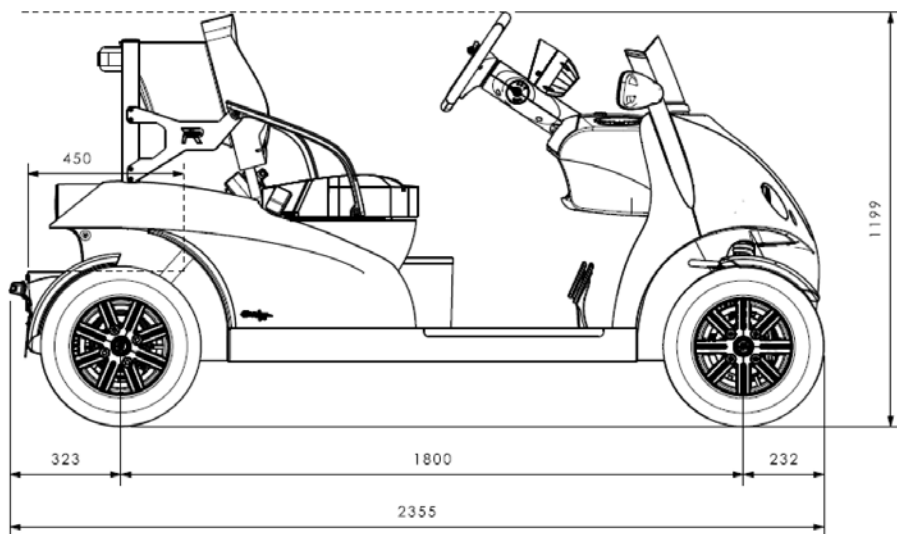



AFTER SALES SUPPORT

Garia A/S
Lunikvej 44
2670 Greve, Denmark
Tel: +45 46 570 580
support@garia.com

GARIA.COM